



Manufacturer & Supplier of Steel Pipe  
Fittings, Flanges & Fasteners



## ADCO FORGE AND FITTINGS PRIVATE LIMITED

An ISO 9001:2015 ISO 14001:2015 ISO 45001:2018 PED 2014/68/EU Certified Company



**ADCO**  
FORGE AND FITTINGS PVT. LTD.

Office No.06 1st Floor Building No. 15 1st Carpenter Street  
C P Tank Mumbai - 400004 India

Mail: [info@adcoforge.com](mailto:info@adcoforge.com) | [www.adcoforge.com](http://www.adcoforge.com)

Tel: +91 22-66595582/66595582/46025379/+91 9930469475

▲ <b>Company Profile</b>	<b>03</b>
▲ <b>Product Range</b>	<b>04</b>
▲ <b>Our Clientele</b>	<b>05</b>
▲ <b>Manufacture Buttweld / Socket Weld / Threaded Fittings &amp; Flanges</b>	<b>06</b>
▲ <b>Dimensions Of Pipes &amp; Tubes</b>	<b>07</b>
▲ <b>Butt-Weld Pipe Fitting</b>	<b>08</b>
▲ <b>Chemical Compositions &amp; Mechanical Properties</b>	<b>09</b>
▲ <b>Butt Welding Pipe Fitting Dimension Standard ANSI B 16.9, B 16.28</b>	<b>10</b>
▲ <b>Dimensional Tolerances as per ANSI B 16.9 / B 16.28 / MSS SP-43 Butt Welding Fitting</b>	<b>11</b>
▲ <b>Forged Fitting</b>	<b>12</b>
▲ <b>Dimension in MM of Forged Screwed &amp; Socket Weld Fittings</b>	<b>13</b>
▲ <b>Chemical &amp; Physical Properties of Flanges Weld Forged Fittings</b>	<b>14</b>
▲ <b>Flanges</b>	<b>15</b>
▲ <b>Dimensions of forged Flanges ANSI B 16.5 (150 / 300) Diagram</b>	<b>16/17</b>
▲ <b>Dimensions of forged Flanges ANSI B 16.5 (600 / 900) Diagram</b>	<b>18/19</b>
▲ <b>Dimensions of forged Flanges ANSI B 16.5 (1500 / 2500) Diagram</b>	<b>20/21</b>
▲ <b>Number &amp; Size of Bolts For Flanged Joints - ASME B16.5</b>	<b>22</b>
▲ <b>Threaded Outlets &amp; Socket Weld</b>	<b>23</b>
▲ <b>Butt-Weld Outlet</b>	<b>24</b>
▲ <b>Lateral &amp; Elbow Connections</b>	<b>25</b>
▲ <b>Swaged Nipple</b>	<b>26</b>
▲ <b>Manufacturing Chart</b>	<b>27</b>
▲ <b>Fastener</b>	<b>28/29</b>
▲ <b>Formula of Weight</b>	<b>30</b>
▲ <b>Application Industry</b>	<b>31</b>

## COMPANY PROFILE

We are a 15 years old company engaged in making quality pipe fittings, flanges and supplying all others ferrous & non ferrous products to the discerning customers in India & Abroad.

With high sense of service to industry, we are happy to publish this product cum technical literature for the use of these quality minded persons involved in the process of purchase or engineers in the process of updating the technology & products from time to time.

With a view in our mind of highlighting the products, it becomes necessary to dwell on various aspects of the products that we make and supply to various industries which are in continuous search of quality products  
Before introducing our products, we would like to answer the obvious question in your mind

Some of the unique values that comes along with Divine products

- + Commitment to complete customer satisfaction
- + Complete product knowledge
- + Total Quality management
- + State of the art manufacturing & assembling facilities
- + Excellent sourcing capability
- + Competitive pricing
- + Prompt & reliable customer services

### OUR PRODUCT RANGE:

Butt weld fittings, Socket weld fittings, Flanges, Fasteners in order to further expand the market and our product offerings we are very actively involved in All stocking & supply of stainless steel, carbon steel, alloy steel in the form of All Forms No wonder we have associated, and a regular supplier to the best of companies from various industries such as

- + Oil & Gas
- + Petrochemicals
- + Agro chemicals
- + Fire safety product
- + Shipping
- + Engineering
- + Dairy & Food processing
- + Pharmaceutical

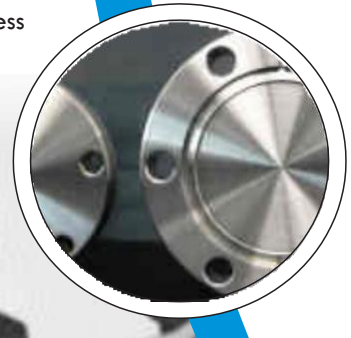



## PRODUCT RANGE



Butt Weld Fitting

**STAINLESS STEEL:** ASTM A403 WP 304 / 304L / 304H / 316 / 316L / 317 / 317L / 321 / 310 / 347 / 904L etc  
**CARBON STEEL:** ASTM A234 WPB/A420, WPL3/A420, WPL6/ MSS-SP-75 WPHY 42/46/52/56/62/65/70.  
**ALLOY STEEL:** ASTM A 234 WP1 / WP5 / WP9 / WP11 / WP22 / WP91 etc.  
**NICKEL ALLOY:** Monel, Nickel, Inconel, Hastalloy, Copper, Brass, Bronze, Titanium, Tantalum, Bismuth, Aluminium, High Speed Steel, Zinc, Lead etc.  
**TYPES:** Elbow, Tee, Reducer, Return Bends, Stub-Ends, Cap, Collar, Cross, Insert etc.  
**SIZE:** 1/4" NB to 48" NB. (Seamless & Welded)  
**WALL THICKNESS:** Sch.5S to Sch. XXS  
**STD:** ANSI / DIN



Flanges

**STAINLESS STEEL:** ASTM A182 F304 / 304L / 304H / 316 / 316L / 317 / 317L / 321 / 310 / 347 / 904L etc  
**CARBON STEEL:** ASTM A105 /A694 F42 / 46 / 52 / 56 / 60 / 65 / 70 / A350 Lf2, etc.  
**LOW TEMPERATURE, CARBON STEEL:** A333 Gr.3/Gr.6 etc.  
**OTHERS:** Monel, Nickel, Inconel, Hastalloy, Copper, Brass, Bronze, Titanium, Tantalum, Bismuth, Aluminium, High Speed Steel, Zinc, Lead etc.  
**TYPES:** Weldneck, Slipon, Blind, Socket Weld, Lap Point, Spectacles, Ring Joint, Oriface, Long Weldneck, Deck Flange, RTJ, Flange.  
**SIZE:** 1/2" NB to 60" NB.  
**WALL THICKNESS:** 150#, 300#, 400#, 600#, 900#, 1500# & 2500#.  
**STD:** ANSI / DIN / EN / BS / JIS.



Forged Socket weld & Screwed Fitting

**STAINLESS STEEL:** ASTM A182 F304 / 304L / 304H / 316 / 316L / 317 / 317L / 321 / 310 / 347 / 904L etc  
**CARBON STEEL:** ASTM A105 /A694 F42 / 46 / 52 / 56 / 60 / 65 / 70 / A350 LF2, etc.  
**ALLOY STEEL:** ASTM A182 F2 / F5 / F9 / F11 / F22 / F91 etc.  
**OTHERS:** Monel, Nickel, Inconel, Hastalloy, Copper, Brass, Bronze, Titanium, Tantalum, Bismuth, Aluminium, High Speed Steel, Zinc, Lead etc.  
**TYPES:** Elbow, Tee, Union, Cross, Coupling, Cap, Bushing, Plug, Swage, Nipple, Welding Boss, Hexagon Nipple, Barrel Nipple, Welding Nipple, Parraler Nipple, Street Elbow, Hexagon Nut, Hose Nipple, Bend, Adapter, Insert, Weldolet, Elbowlet, Sockolet, Thredolet, Nipolet, Letrolet, etc.  
**SIZE:** 1/4" NB to 4" NB.  
**CLASS:** 3000#, 6000#, 9000#.



Fasteners

**STAINLESS STEEL:** AISI 302, 304, 304l, 316, 316L, 310, 317, 317L, 321, 347, 410, 420, 904L etc  
**CARBON STEEL:** Bare Condition, Galvanized Phosphetised, Cadium Plated, Hot Deep Gavanized, Bloodied, Nickel Chrome Plated etc.  
**ALLOY STEEL:** 4.6, 5.6, 6.6, 8.8, 10.9, & 12.9 / 'R', 'S', 'T' Conditions.  
**NON FERROUS METAL:** Copper, Brass, Aluminium, Titanium, Nichrome, Al.Bronze Phosphoros Bronze, etc  
**TYPES:** Bolt, Nuts, Washer, Anchor Fastener, Stud Bolts, Eye Bolt, Stud, Threaded Rod, Cotter Pin, Socket Screw, Fine Fasteners & Spares, Foundation Fasteners etc.



## OUR CLIENTELE

## THIRD PARTY INSPECTION

--	--	--	--	--	--



## Manufacturing

### Buttweld / Socketweld / Threaded Fittings & Flanges

This is introduce ourselves as the most reliable outsourcing partners for manufacturing of buttwelding pipe fittings, socket weld, pipe fittings, flanges & tubular components in all kinds of steel. Our panel of experienced manufacturers ensures excellent quality fittings meeting exacting standards of National & International quality.

These Pipe Fitting are manufactured from ferrous metal such as Carbon Steel, Alloy Steel, Low Temperature Carbon Steel & Stainless Steel. Both Seamless and E.R.W. Pipe Fittings are Produced by our special manufacturing process involving either hot or cold forming. We are fully capable of manufacturing Pipe fittings made to customer's specifications in terms of type, dimensions, material & quantity under any third party inspection.

These Pipe Fittings are perfectly round, rugged, leak proof, corrosion resistant (Where ever required), meeting all the requirements to ASA/BS/DIN/ISI codes. These quality fittings extend the life of piping systems, facilitate direct pipe welding, permit compact installations & reduce the space necessary for installing a piping network

### FACILITIES

- Hydraulic Press**
- Plate Rolling Machines**
- Oil Fried Furnace with Temp. Recorder**
- Grinding Machines**
- Universal Testing Machine**
- Drilling Machine**
- Hardness Tester**
- Motore Generator Welding sets**
- Chemical Laboratory**
- AC Rectifier Welding Sets**
- Hacksaw cutting Machines**
- Computer & Software**
- Lathe Machines**



### DIMENSION OF PIPES & TUBES

DIMENSION ANSI B 36-10			DIMENSION ANSI B 36-10											DIMENSION ANSI B 36-10		
Size of Pipes & Tubes	Nominal Thickness and Weight		Nominal Thickness and Weight													
	Number of Schedule		Number of Schedule													
	5S	10S	10	20	30	40	60	80	100	120	140	160	Standard	Extra Strong	Double Extra Strong	
mm	mm	mm	mm	mm	mm	mm	mm	mm	mm	mm	mm	mm	mm	mm	mm	
in	in	in	in	in	in	in	in	in	in	in	in	in	in	in	in	
18"	10.3	1.28	0.28	1.60	0.345	1.73	0.36	2.41	0.46	2.41	0.46	1.73	0.36	2.41	0.46	-
14"	13.7	1.65	0.49	2.00	0.580	2.24	0.63	3.02	0.80	3.02	0.80	2.24	0.63	3.02	0.80	-
38"	17.1	1.65	0.63	2.00	0.750	2.31	0.85	3.20	1.10	3.20	1.10	2.31	0.85	3.20	1.10	-
12"	21.3	1.65	1.00	2.00	0.957	2.77	1.26	3.73	1.62	3.73	1.62	2.77	1.26	3.73	1.62	2.54
34"	26.7	1.65	1.28	2.50	1.500	2.87	1.68	9.91	2.19	9.91	2.19	2.87	1.68	9.91	2.19	3.63
1"	33.4	1.65	2.08	2.50	1.916	3.38	2.5	4.55	3.23	4.55	3.23	3.38	2.5	4.55	3.23	5.45
11/4"	42.2	1.65	2.69	3.00	2.910	3.56	3.38	4.85	4.46	4.85	4.46	3.56	3.38	4.85	4.46	7.75
11/2"	48.3	1.65	3.12	3.00	3.370	3.68	4.05	5.08	5.40	5.08	5.40	3.68	4.05	5.08	5.40	9.54
2"	60.3	1.65	3.94	4.00	4.263	3.91	5.43	7.01	11.40	7.01	11.40	4.00	5.43	7.01	11.40	13.44
2 1/2"	73.0	2.11	5.26	4.00	6.496	5.16	8.62	11.13	15.25	11.13	15.25	4.00	8.62	11.13	15.25	20.29
3"	88.9	2.11	6.45	4.00	8.423	5.49	11.29	14.27	20.95	14.27	20.95	4.00	11.29	14.27	20.95	27.65
3 1/2"	101.6	2.11	7.40	4.50	10.838	5.74	13.56	17.48	22.29	17.48	22.29	4.50	13.56	17.48	22.29	30.92
4"	114.3	2.11	8.34	4.50	12.555	6.02	16.06	19.05	25.40	19.05	25.40	4.50	16.06	19.05	25.40	33.92
5"	141.3	2.77	11.56	5.00	16.900	6.55	21.76	21.44	30.92	21.44	30.92	5.00	21.76	21.44	30.92	40.99
6"	168.3	2.77	13.82	6.35	24.150	7.11	28.23	25.40	42.52	25.40	42.52	6.35	28.23	25.40	42.52	57.37
8"	219.1	2.77	19.94	6.35	33.28	8.18	42.49	30.92	57.37	30.92	57.37	6.35	42.49	30.92	57.37	79.11
10"	273.0	3.40	27.83	6.35	41.73	9.27	60.24	33.32	79.11	33.32	79.11	6.35	60.24	33.32	79.11	107.78
12"	323.9	3.96	36.00	6.35	49.68	10.31	79.71	37.87	107.78	37.87	107.78	6.35	79.71	37.87	107.78	146.75
14"	355.6	3.96	41.18	6.35	54.63	11.13	94.31	40.81	127.0	40.81	127.0	6.35	94.31	40.81	127.0	171.18
16"	409.4	4.19	47.33	6.35	62.58	12.70	123.18	45.71	152.4	45.71	152.4	6.35	123.18	45.71	152.4	202.65
18"	457.2	4.19	53.18	7.92	77.92	14.27	155.90	50.81	182.9	50.81	182.9	7.92	155.90	50.81	182.9	244.44
20"	508.0	4.78	68.50	9.52	116.67	15.09	183.14	55.90	212.4	55.90	212.4	9.52	183.14	55.90	212.4	286.22
22"	558.8	4.78	73.81	9.52	128.89	17.48	205.62	61.00	241.9	61.00	241.9	9.52	205.62	61.00	241.9	328.01
24"	609.6	5.54	82.60	9.52	140.81	17.48	229.80	66.10	271.4	66.10	271.4	9.52	229.80	66.10	271.4	370.00
26"	660.4	-	-	7.92	127.58	12.70	205.62	51.80	241.9	51.80	241.9	7.92	205.62	51.80	241.9	320.00
28"	711.2	-	-	7.92	137.52	12.70	218.54	56.90	271.4	56.90	271.4	7.92	218.54	56.90	271.4	370.00
30"	762.0	-	-	7.92	147.45	12.70	234.44	62.00	301.9	62.00	301.9	7.92	234.44	62.00	301.9	420.00
32"	812.8	-	-	7.92	157.38	12.70	250.33	67.10	332.4	67.10	332.4	7.92	250.33	67.10	332.4	470.00
34"	863.6	-	-	7.92	167.32	12.70	266.22	72.20	362.9	72.20	362.9	7.92	266.22	72.20	362.9	520.00
36"	914.4	-	-	7.92	177.26	12.70	282.12	77.30	393.4	77.30	393.4	7.92	282.12	77.30	393.4	570.00

N.B. : Thickness and weights "standard" "Extra strong" & "double extra strong" within swell edges have a correspondent value in "Schedule" for different thickness that suitable the weights can proceeds by following formula 24.66 (d.t.)



# BUTT-WELD PIPE FITTING



## BUTT-WELD FITTINGS CHEMICAL COMPOSITION & MECHANICAL PROPERTIES

Steel Type	ASTM GRADE	Chemical Composition & Mechanical Properties									Mechanical Properties				
		C% max	Mn %	P% max	S% max	Si %	Cr %	Mo %	Ni %	Other	R.min. Tensile Strength MPa	S.min. Yield Strength Mpa	A% min. (2"/4D) Elongation		Impact test KCV (2) J
													Long	Trans v	
A234	WPB(1)	0.3	0.29-1.06	0.05	0.058	0.10min	0.4	0.15	0.4	cu=0.4 v=0.08, cb=0.02	415-585	240	30	20	-
	WPC(1)	0.35	0.29-1.06	0.05	0.058	0.10	0.4	0.15	0.4	cu=0.4 v=0.08, cb=0.02	485-655	275	30	20	-
A420	WPL/6(1)	0.3	0.6-1.35	0.035	0.04	0.15-0.30	0.3	0.12	0.4	cu=0.4 v=0.08, cb=0.02	415-585	240	30	16.5	-45°C17.6/13.6
	WPL3	0.2	0.31-0.64	0.05	0.05	0.13-0.37	-	-	3.2-3.8	-	450-620	240	30	20	-101°C17.6/13.6
A234	Wp1	0.28	0.30-0.9	0.045	0.045	0.10-0.50	-	0.44-0.65	-	-	380-550	205	30	20	-
	WP12CL1	0.05-0.2	0.3-0.8	0.045	0.045	0.6	0.8-1.25	0.44-0.65	-	-	415-585	220	30	20	-
	WP12CL2	-	-	-	-	-	-	-	-	-	485-655	275	30	20	-
	WP11CL1	-0.5-0.15	0.03-0.6	0.3	0.3	0.5-10	1.0-1.5	0.44-0.65	-	-	415-585	205	30	20	-
	WP11CL2	0.5-0.2	0.3-0.8	0.4	0.4	0.5-10	1.0-1.5	0.44-0.65	-	-	485-655	275	30	20	-
	WP11CL3	-	-	-	-	-	-	-	-	-	520-690	310	30	20	-
	WP22CL1	0.05-0.15	0.3-0.6	0.04	0.04	0.5	1.9-2.6	0.87-113	-	-	415-585	205	30	20	-
	WP22CL3	-	-	-	-	-	-	-	-	-	520-690	310	30	20	-
	Wp5	0.15	0.3-0.6	0.04	0.03	0.5	4.0-6.0	0.44-0.65	-	-	415-585	205	30	20	-
	Wp9	0.15	0.6-0.6	0.03	0.03	0.25-10	8.0-10.0	0.9-1.10	-	-	415-585	205	30	20	-
A403	Wp91	0.08-0.12	0.6-0.6	0.02	0.01	0.2-0.5	8.0-9.5	0.85-1.05	0.4	V=0.18-0.25 CB=0.06-0.10 N=0.03-0.07 Al=0.04	585-760	415	20	-	-
	Wp304	0.08	2	0.045	0.03	1	18-20	-	8.0-11.0	-	515	205	28	20	-
	WP304L	0.035	2	0.045	0.03	1	18-20	-	8.0-13.0	-	485	170	28	20	-
	WP304H	0.04-0.10	2	0.045	0.03	1	18-20	-	8.0-11.0	-	515	205	28	20	-
	Wp316	0.08	2	0.045	0.03	1	18-20	2.0-3.0	11.0-14.0	-	515	205	28	20	-
	WP316L	0.035	2	0.045	0.03	1	18-20	2.0-3.0	10.0-16.0	-	485	170	28	20	-
	Wp321	0.08	2	0.045	0.03	1	17.0-20.0	-	9.0-13.0	Ti=5xC max 0.70%	515	205	28	20	-
	WP321H	0.04-0.10	2	0.045	0.03	1	17.0-20.0	-	9.0-13.0	Ti=4xC max 0.60%	515	205	28	20	-
	Wp347	0.08	2	0.045	0.03	1	17.0-20.0	-	9.0-13.0	cb+ta=10.5% max 0.10%	515	205	28	20	-
	WP347H	0.04-0.10	2	0.045	0.03	1	17.0-20.0	-	9.0-13.0	cb+ta=8% max 0.10%	515	205	28	20	-
A815	WPS31254	0.02	1	0.03	0.01	0.8	19.5-20.5	6.0-6.5	17.5-18.5	N=0.18-0.22 Cu=0.5-1.0	515	205	28	20	-
	S 31803	0.03	2	0.03	0.02	1	21.0-23.0	2.5-3.5	4.5-6.5	N=0.08-0.2	620	450	25	-	-
B366	Wp410	0.15	1	0.04	0.03	1	15.5-13.5	-	0.5	-	485-655	205	20	-	-
	WPNIC10	0.06-0.10	1.5		0.015	1	19.0-23.0	-	30.0-35.0	Cu=0.75	450	170	30		
	WPNIC11	0.06-0.10	1.5		0.015	1	19.0-23.0	-	30.0-35.0	Al=0.15-0.60 Ti=0.15-0.60 Fe=35.5min AL+Ti=0.85-1.20	450	170	30		





### BUTT WELDING PIPE FITTING DIMENSIONAL STANDARD ANSI B-16.9 AND B-16.28

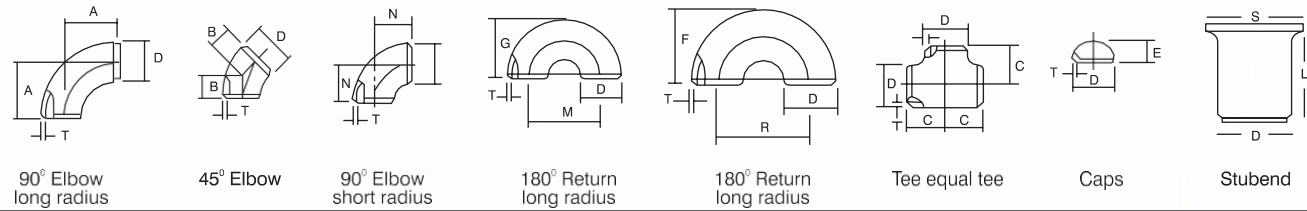

Nominal pipe size		Outside Diameter D	Centre to face				Back to Face			Centre to Centre			Length 'L'	
Inch	mm		A	B	C	N	E	F	G	R	M	S	MSS SP 43	ANSI B 16.9
1/2	15	21.3	19	16	25		25	48		38		34.9	50.8	76.2
3/4	20	26.7	29	11	29		25	43		57		42.8	50.8	76.2
1	25	33.4	38	22	38	25	38	56	41	76	51	50.8	50.8	101.6
1. 1/4	32	42.2	48	25	48	32	38	70	52	95	64	63.5	50.8	101.6
1. 1/2	40	48.3	57	29	57	38	38	83	62	114	76	73	50.8	101.6
2	50	60.3	76	35	64	51	38	106	81	152	102	92	63.5	152.4
2. 1/2	65	73.0	95	44	76	64	38	132	100	191	127	104.8	63.5	152.4
3	80	88.9	114	51	86	76	51	159	121	229	152	127	63.5	152.4
3. 1/2	90	101.6	133	57	95	89	64	184	140	267	178	139.7	76.2	152.4
4	100	114.3	152	64	105	102	64	210	159	305	203	157.2	76.2	152.4
5	125	141.3	190	79	124	127	76	262	197	381	254	185.7	76.2	203.2
6	150	168.3	229	95	143	152	89	313	237	457	305	215.9	88.9	203.2
8	200	219.1	305	127	178	203	102	414	313	610	406	270	101.6	203.2
10	250	273.1	381	159	216	254	127	518	391	762	508	324	127.0	254.0
12	300	323.9	457	190	254	305	152	619	467	914	610	381	152.4	254.0
14	350	355.6	533	222	279	356	165	711	533	1067	711	412.8	152.4	305.0
16	400	406.4	610	254	305	406	178	813	610	1219	813	470	152.4	305.0
18	450	457.0	689	286	343	457	203	914	686	1372	914	533.4	152.4	305.0
20	500	508.0	762	318	381	508	229	1016	762	1524	1016	584.2	152.4	305.0
22	550	559.0	838	343	419	559	254	1118	838	1676	1118	614.4	152.4	305.0
24	600	610.0	914	381	432	610	267	1219	914	1829	1219	692.2	152.4	305.0
26	650	660.0	991.0	406.0	495	660	267							
28	700	711.0	1067.0	438.0	521	711	267							
30	750	762.0	1143.0	470.0	559	762	267							
32	800	813.0	1219	502.0	597	813	267							
34	850	864.0	1295.0	533.0	635	864	267							
36	900	914.0	1372.0	565.0	673	914	267							
38	950	965.0	1448.0	600.0	711	965	305							
40	1000	1016.0	1524.0	632.0	749	1016	305							
42	1050	1067.0	1600.0	660.0	762	1067	305							
44	1100	1118.0	1676.0	695.0	813	1118	343							
46	1150	1168.0	1753.0	727.0	851	1168	343							
48	1200	1219.0	1829.0	759.0	889	1219	343							



### DIMENSIONAL TOLERANCES AS PER ANSI B 16.9/B 16.28/ MSS SP-43 FOR BUTT WELD FITTINGS

All Fittings	Nominal Pipe Size (NPS)	Outside dia at Bevel (1), (2) D	Inside dia at End (1), (2), (3)	Wall Thickness (3)	Center to end Dimension A, B, C, M	Center to Overall Length F, H	Overall Length E	Caps	180 deg Returns	Lap Joint Stub Ends				
										Center to Center Dimension O	Back to Face Dimension K	Alignment of ends U	Outside Diameter of Lap G	Fillet Radius of Lap R
	1/2 to 2/12		1	0.8	Not less than 87.5% of nominal thickness	2	2	4	7	7	1	+0.1	+0.1	See Table 7 for limiting dimensions
	3 to 3/12		1	1.6		2	2	4	7	7	1	+0.1	+0.1	
	4	+2	-1	1.6		2	2	4	7	7	1	+0.1	+0.1	
	5 to 6	-3	-1	1.6		2	2	7	7	7	1	+0.1	+0.2	
	8	+4	-3	1.6		2	2	7	7	7	1	+0.1	+0.2	
	10	+4	-3	3.2		2	2	7	10	7	2	+0.2	+0.2	
	12 to 18	+4	-3	3.2		2	2	7	10	7	2	+0.2	+0.2	
	20 to 24	+6	-5	4.8		3	3	7	10	7	2	+0.2	+0.2	
	26 to 30	+7	-5	4.8		3	3	10	--	--	--	--	--	
	32 to 48	+7	-5	4.8		5	5	10	--	--	--	--	--	

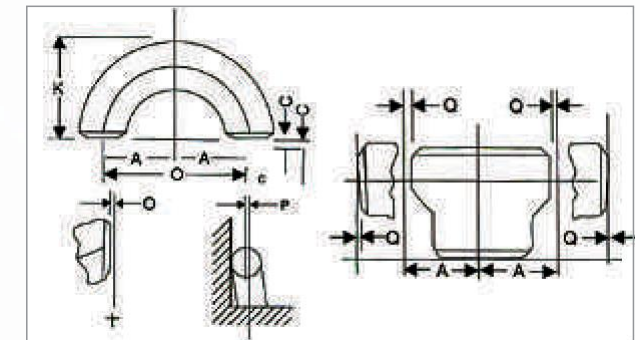
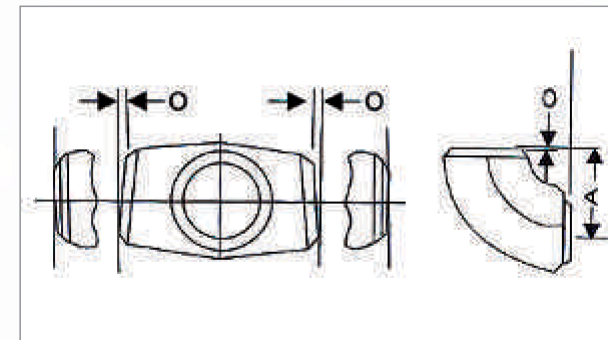



# FORGED FITTING



## DIMENSION IN MM OF FORGED SCREWED FITTINGS TO ANSI B - 16.11 THREADED TO ASA B 2.1

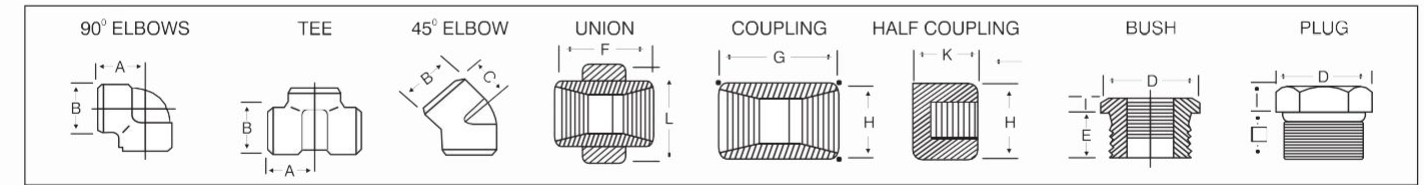

Nom. Bore	Pipe O. D.	3000 L.B.S.						COMMON FACTORS						6000 L.B.S.					
		A	B	C	G	H	K	D	E	F	I	J	L	A	B	C	G	H	K
1/8"	10.3	21	22	17	32	16	19	11	10	40		6		25	25	19	32	22	
1/4"	13.7	25	25	19	35	19	25	16	11	43	3	6	32	29	33	22	35	25	27
3/8"	17.2	29	33	22	38	22	25	17.5	13	48	4	8	38	33	38	25	38	32	27
1/2"	21.3	33	38	25	48	29	32	22	15	51	5	8	46	38	46	29	48	38	33
3/4"	26.7	38	46	29	51	35	37	27	16	57	6	10	51	44	56	33	51	44	38
1"	33.4	44	56	33	60	44	41	35	19	64	6	10	60	51	62	35	60	57	43
1 1/4"	42.2	51	62	35	67	57	44	44.5	21	70	7	14	72	60	75	43	67	64	46
1 1/2"	48.3	60	75	43	79	64	44	51	21	79	8	16	80	64	84	44	79	76	48
2"	60.3	64	84	45	86	76	48	63.5	22	88	9	17	94	83	102	52	86	92	51
2 1/2"	73.02	83	102	52	92	92	60	76	27	118	10	21	122	95	121	64	92	108	64
3"	89.0	95	121	64	108	108	65	89	29	121	10	25	140	106	146	79	108	127	68
4"	114.5	114	152	79	121	140	68	117.5	32	150	13	25	180	114	152	79	121	159	75

## DIMENSION IN MM OF SOCKET WELD FITTINGS TO ANSI B - 16.11

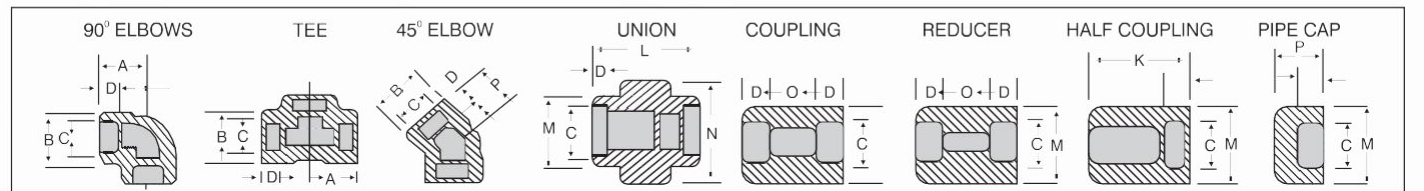

Nom. Bore	Pipe O. D.	3000 L.B.S.						COMMON FACTORS						6000 L.B.S.					
		A max	B max	K	J	L	M	N	P	Q	C MIN	D MIN	O MIN	O MAX	A	B	M	K	N
1/8"	10.3	22	18.5	26	16	40	17.3	32	17.5	10	10.7	10	5	8	22	22	20	25	46
1/4"	13.7	22	22	26	18	43	21.2	32	17.5	10	14.1	10	5	8	27	25	24	25	51
3/8"	17.2	25	25	26	19	48	25.4	36	19	10	17.6	10	3	9	27	28	28	26	60
1/2"	21.3	27	32	30	21	51	31	43	22	10	21.7	10	6	13	31	34	34	31	72
3/4"	26.7	34	38	36	24	57	37	50	25	13	27	13	6	13	37	42	41	35	80
1"	33.4	37	46	40	25	64	45.2	60	27	13	33.8	13	9	17	42	50	50	40	94
1 1/4"	42.2	42	56	40	29	70	55	70	30	13	42.6	13	9	17	47	59	58	41	100
1 1/2"	48.3	47	62	40	30	79	61.4	78	32	13	48.7	13	9	17	53	67	66	43	122
2"	60.3	56	75	52	37	89	75	95	38	13	61.2	16	15	23	59	84	83	55	
2 1/2"	73.02	60	92	52	48	114	91.3	125	38	16	73.8	16	14	24		102		56	
3"	89.0	76	110	52	51	127	108.8	140	44	16	89.8	16	14	24		121		58	
4"	114.5	88	137	58		150	136.9		48	19	115.5	19	14	24		152		64	



MATERIAL SPECIFICATION FOR FORGED FITTING & FLANGES

ASTM	Identification Symbol	C	Mn	P	S	Si	Ni	Cr	Mo	Ti	Other Elements	TS Min Ksi(Mpa)	YS Min Ksi(Mpa)	EL Min%	Rrad Min%	HB
A105*		MAX 0.35	0.60-1.05	MAX 0.035	MAX 0.040	0.10-0.35	MAX 0.040	MAX 0.30	MAX 0.12			70(485)	36(250)	30	30	MAX 187
A182	F1	0.28	0.60-0.90	0.045	0.045	0.15-0.35			0.44-0.65			70(485)	40(275)	20	30	143-192
A182	F5	0.15	0.30-0.60	0.030	0.030	0.50	0.50	4.0-6.0	0.44-0.65			70(485)	40(275)	20	35	143-217
A182	F5A	0.25	0.60	0.040	0.030	0.50	0.50	4.0-6.0	0.44-0.65			22	50	187-248	90(620)	65(450)
A182	F9	0.15	0.30-0.60	0.030	0.030	0.50-1.00		8.0-10.0	0.90-1.10			85(585)	55(380)	20	40	179-217
A182*	F91	0.08-0.12	0.30-0.60	0.020	0.010	0.20-0.50	0.40	8.0-9.5	0.85-1.05			85(585)	60(415)	20	40	MAX 248
A182	F11 CL1	0.05-0.15	0.30-0.60	0.030	0.030	0.50-1.00		1.00-1.50	0.44-0.65			60(415)	30(205)	20	45	121-174
A182	F11 CL2	0.10-0.20	0.30-0.80	0.040	0.040	0.50-1.00		1.00-1.50	0.44-0.65			70(485)	40(275)	20	30	143-207
A182	F11 CL3	0.10-0.20	0.30-0.80	0.040	0.040	0.50-1.00		1.00-1.50	0.44-0.65			75(515)	45(310)	20	30	156-207
A182	F12 CL1	0.05-0.15	0.30-0.60	0.045	0.045	MAX 0.50		0.80-1.25	0.44-0.65			60(415)	32(220)	20	45	121-174
A182	F12 CL2	0.10-0.20	0.30-0.80	0.040	0.040	0.10-0.60		0.80-1.25	0.44-0.65			70(485)	40(275)	20	30	143-207
A182	F22 CL1	0.05-0.15	0.30-0.60	0.040	0.040	0.50		2.00-2.50	0.87-1.13			60(415)	30(205)	20	35	max 170
A182	F22 CL3	0.05-0.15	0.30-0.60	0.040	0.040	0.50		2.00-2.50	0.87-1.13			75(515)	45(310)	20	30	156-207
A182	F304	0.08	2.00	0.045	0.030	1.00	8.0-11.0	18.0-20.0				75(515)	30(205)	30	50	
A182	F304L	0.030	2.00	0.045	0.030	1.00	8.0-13.0	18.0-20.0				70(485)	25(170)	30	50	
A182	F316	0.08	2.00	0.045	0.030	1.00	10.0-14.0	16.0-18.0	2.00-3.00			75(515)	30(205)	30	50	
A182	F316L	0.030	2.00	0.045	0.030	1.00	10.0-15.0	16.0-18.0	2.00-3.00			70(485)	25(170)	30	50	
A182	F317	0.08	2.00	0.045	0.030	1.00	11.0-15.0	18.0-20.0	3.0-4.0			75(515)	30(205)	30	50	
A182	F317L	0.030	2.00	0.045	0.030	1.00	11.0-15.0	18.0-20.0				70(485)	25(170)	30	50	
A182	F321	0.08	2.00	0.045	0.030	1.00	9.0-12.0	17.0-19.0		Cx5-0.7		75(515)	30(205)	30	50	
A182	F321H	0.04-0.10	2.00	0.045	0.030	1.00	9.0-12.0	17.0-19.0		Cx4-0.7		75(515)	30(205)	30	50	
A182	F347	0.08	2.0	0.045	0.030	1.00	9.30-12.0	17.0-20.0			Cb-10xC-1.0	75(515)	30(205)	30	50	
A182	F347H	0.04-0.10	2.0	0.045	0.030	1.00	9.0-13.0	17.0-20.0			Cb-8xC-1.1	75(515)	30(205)	30	50	
A182	F51	0.03	2.00	0.030	0.020	1.00	4.5-6.5	21.0-23.0	2.5-3.5		N 0.08-0.20	90(620)	65(450)	25	45	
A350*	LF1	0.30	0.60-1.35	0.035	0.040	0.15-0.30	MAX 0.40	MAX 0.30	MAX 0.12			60-85 (415-585)	30(205)	25	38	
A350*	LF2	0.30	0.60-1.35	0.035	0.040	0.15-0.30	MAX 0.40	MAX 0.30	MAX 0.12			70-95 (485-655)	36(250)	22	30	
A350*	LF3	0.20	MAX 0.90	0.035	0.040	0.20-0.35	3.3-0.35	MAX 0.30	MAX 0.12			70-95 (485-655)	37.5(260)	22	35	

# FLANGES

ANSI / EN / DIN / BS / JIS / UN / AEI TYPE FLANGES  
STAINLESS STEEL





### ASME/ANSI B16.5 DIMENSION OF CLASS 150 & 300 FLANGES

Note: This Diagram illustrates the Correct Position but not Necessarily the Correct

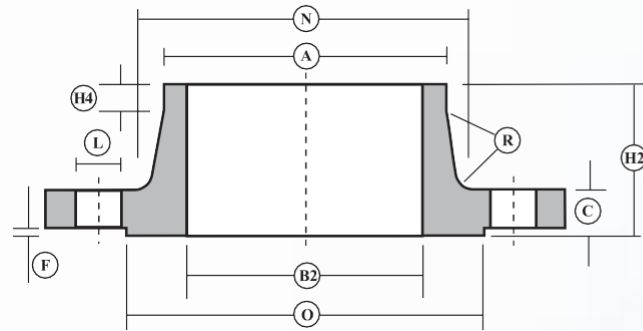
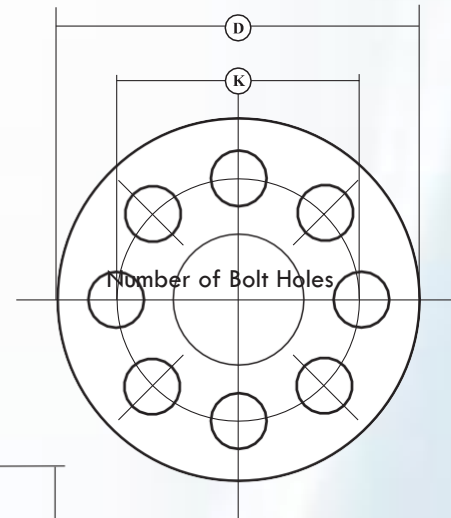

Steel Welding Neck Flange

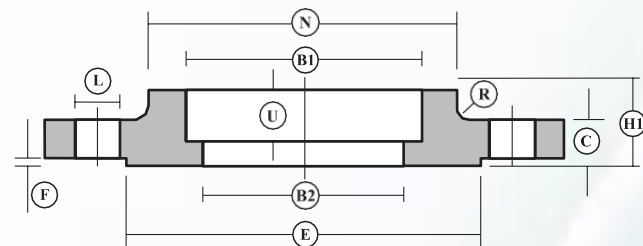

Socket Welding Flange

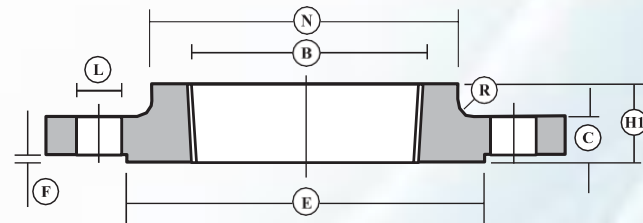

Screwed Boss Flange

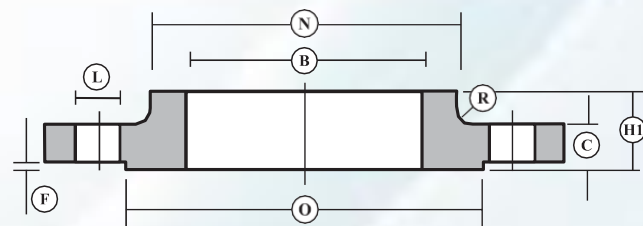

Slip-on Boss Flange

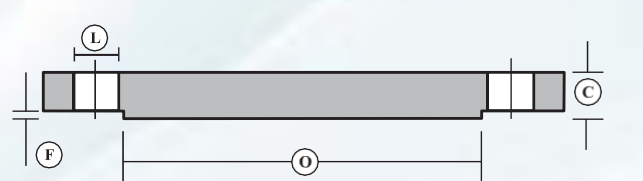

Steel Plate Blind Flange

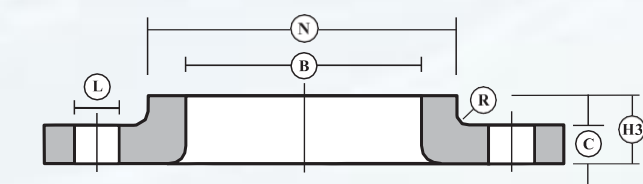

Lapped Flange

### ASME/ANSI B16.5 Dimensions of Class 150 Flanges

N B Size INS MM	D	K	L	A	C	N	H1	H2	H3	H4	T	B1	B2	B3	R	R1	U	O	F	No. Holes
1/2 15	89	60.3	15.9	21.3	11.1	30	15.9	47.6	15.9	Min 6.4mm Schedule to be supplied by purchaser	15.9	22.4	23	3	3	9.5	34.9	1.6	4	
3/4 20	98	69.8	15.9	26.7	12.7	38	15.9	52.4	15.9		15.9	27.7	28	3	3	11	42.9	1.6	4	
1 25	108	79.4	15.9	33.4	14.3	49	17.5	55.6	17.5		17.5	34.5	35	3	3	12.5	50.8	1.6	4	
1 1/4 32	117	88.9	15.9	42.2	15.9	59	20.6	57.2	20.6		20.6	43.2	43.5	3	5	14.5	63.5	1.6	4	
1 1/2 40	127	98.4	15.9	48.3	17.5	65	22.2	61.9	22.2		22.2	49.5	50	3	6.5	16	73	1.6	4	
2 50	152	120.6	19	60.3	19	78	25.4	63.5	25.4		25.4	62	62.5	3	8	17.5	92.1	1.6	4	
2 1/2 65	178	139.7	19	73	22.2	90	28.6	69.9	28.6		28.6	74.7	75.5	3	8	19	104.8	1.6	4	
3 80	190	152.4	19	88.9	23.8	108	30.2	69.9	30.2		30.2	90.7	91.5	3	9.5	20.5	127	1.6	4	
*3 1/2 88	215.9	177.8	19	101.6	23.8	122	31.8	71.4	31.8		31.8	103.4	104.1	3	9.7	-	139.7	1.6	8	
4 100	229	190.5	19	114.3	23.8	135	33.3	76.2	33.3		33.3	116.1	117	3	11	-	157.2	1.6	8	
5 125	254	215.9	22.2	141.3	23.8	164	36.5	88.9	36.5		36.5	143.8	145	6.5	11	-	185.7	1.6	8	
6 150	279	241.3	22.2	168.3	25.4	192	39.7	88.9	39.7		39.7	170.7	171	6.5	12.5	-	215.9	1.6	8	
8 200	343	298.4	22.2	219.1	28.6	246	44.5	101.6	44.5		-	221.5	222	6.5	12.5	-	269.9	1.6	8	
10 250	406	362	25.4	273	30.2	305	49.2	101.6	49.2		-	276.4	277	6.5	12.5	-	323.8	1.6	12	
12 300	483	431.8	25.4	323.9	31.8	365	55.6	114.3	55.6		-	327.2	328	9.5	12.5	-	381	1.6	12	
14 350	533	476.2	28.6	355.6	34.9	400	57.2	127	79.4	-	359.2	360	9.5	12.5	-	412.7	1.6	12		
16 400	597	539.8	28.6	406.4	36.5	457	63.5	127	87.3	-	410.5	411	9.5	12.5	-	469.9	1.6	16		
18 450	635	577.8	31.8	457.2	39.7	505	68.3	139.7	96.8	-	461.8	462	9.5	12.5	-	533.4	1.6	16		
20 500	698	635	31.8	508	42.9	559	73	144.5	103.2	-	513.1	514	9.5	12.5	-	584.2	1.6	20		
24 600	813	749.3	34.9	609.6	47.6	664	82.6	152.4	111.1	-	616	616	9.5	12.5	-	692.1	1.6	20		

Note: 3.5 Nominal bore Dimensions are Specified only in ASME/ANSI B16.5

### ASME/ANSI B16.5 Dimensions of Class 300 Flanges

N B Size INS MM	D	K	L	A	C	N	H1	H2	H3	H4	T	B1	B2	B3	R	R1	U	O	F	No. Holes
1/2 15	95	66.7	15.9	21.3	14.3	38	22.2	52.4	22.2	Min 6.4mm Schedule to be supplied by purchaser	16	22.4	23	3	3	9.5	34.9	1.6	4	
3/4 20	117	82.6	19	26.7	15.9	48	25.4	57.2	25.4		16	27.7	28	3	3	11	42.9	1.6	4	
1 25	124	88.9	19	33.4	17.5	54	27	61.9	27		17	34.5	35	3	3	12.5	50.8	1.6	4	
1 1/4 32	133	98.4	19	42.2	19	64	27	65.1	27		21	43.2	43.5	3	5	14.5	63.5	1.6	4	
1 1/2 40	156	114.3	22.2	48.3	20.6	70	30.2	68.3	30.2		22	49.5	50	3	6.5	16	73	1.6	4	
2 50	165	127	19	60.3	22.2	84	33.3	69.9	33.3		29	62	62.5	3	8	17.5	92.1	1.6	8	
2 1/2 65	190	149.2	22.2	73	25.4	100	38.1	76.2	38.1		32	74.7	75.5	3	8	19	104.8	1.6	8	
3 80	210	168.3	22.2	88.9	28.6	117	42.9	79.4	42.9		32	90.7	91.5	3	9.5	20.5	127	1.6	8	
*3 1/2 88	228.6	184.2	22.4	101.6	30.2	133.4	44.5	81	44.5		36.6	103.4	104.1	3	9.7	-	139.7	1.6	8	
4 100	254	200	22.2	114.3	31.8	146	47.6	85.7	47.6		37	116.1	117	3	9.5	-	157.2	1.6	8	
5 125	279	235	22.2	141.3	34.9	178	50.8	98.4	50.8		43	143.8	145	6.5	11	-	185.7	1.6	8	
6 150	318	269.9	22.2	168.3	36.5	206	52.4	98.4	52.4		46	170.7	171	6.5	12.5	-	215.9	1.6	12	
8 200	381	330.2	25.4	219.1	41.3	260	61.9	111.1	61.9		-	221.5	222	6.5	12.5	-	269.9	1.6	12	
10 250	444	387.4	28.6	273	47.6	321	66.8	117.5	95.3		-	276.4	277	6.5	12.5	-	323.8	1.6	16	
12 300	521	450.8	31.8	323.9	50.8	375	73	130.2	101.6		-	327.2	328	9.5	12.5	-	381	1.6	16	
14 350	584	514.4	31.8	355.6	54	425	76.2	142.9	111.1	-	359.2	360	9.5	12.5	-	412.7	1.6	20		
16 400	648	571.5	34.9	406.4	57.2	483	82.6	146.1	120.7	-	410.5	411	9.5	12.5	-	469.9	1.6	20		
18 450	711	628.6	34.9	457.2	60.3	533	88.9	158.8	130.2	-	461.8	462	9.5	12.5	-	533.4	1.6	24		
20 500	775	685.8	34.9	508	63.5	587	95.3	162	139.7	-	513.1	514	9.5	12.5	-	584.2	1.6	24		
24 600	914	812.8	41.3	609.6	69.8	702	106.4	168.3	152.4	-	616	616	9.5	12.5	-	692.1	1.6	24		

Note: 3.5 Nominal bore Dimensions are Specified only in ASME/ANSI B16.5

### ASME/ANSI B16.5-1988 DIMENSION OF CLASS 600 & 900 FLANGES

**Note:** This Diagram illustrates the Correct Position but not Necessarily the Correct Number of Bolt Holes

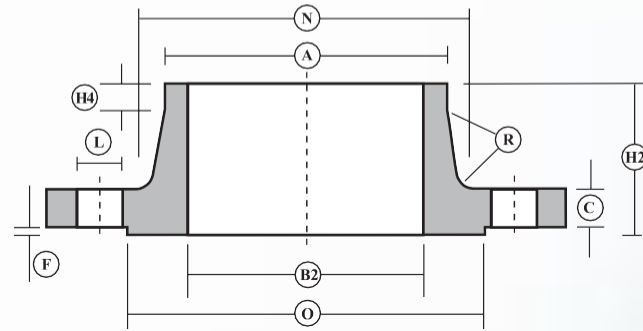
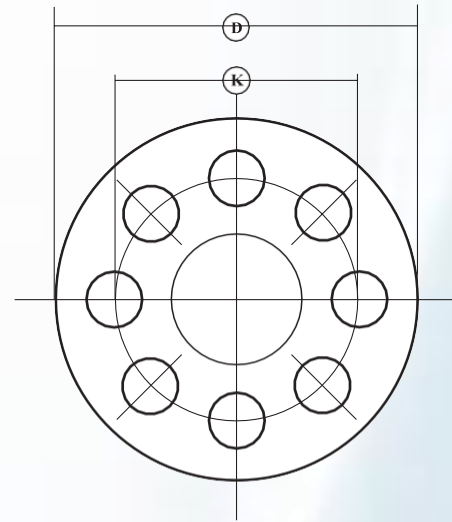

Steel Welding Neck Flange

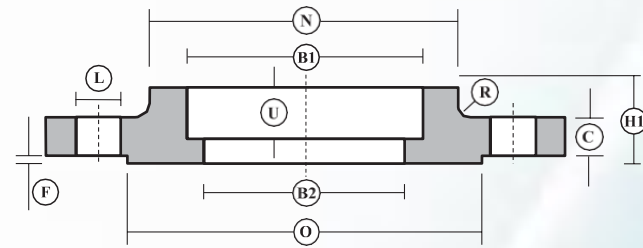

Socket Welding Flange

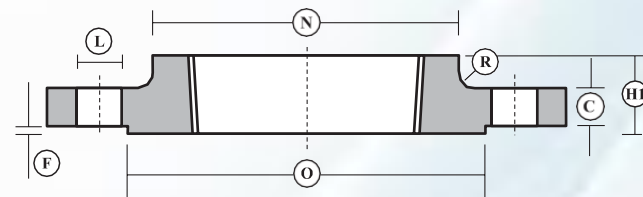

Screwed Boss Flange

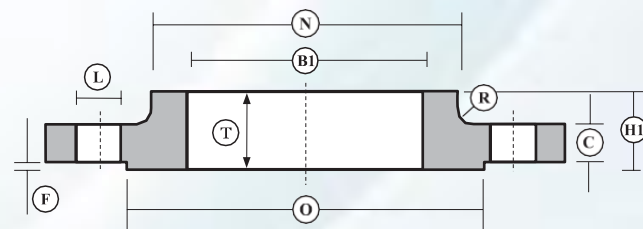

Slip-on Boss Flange



Steel Plate Blind Flange

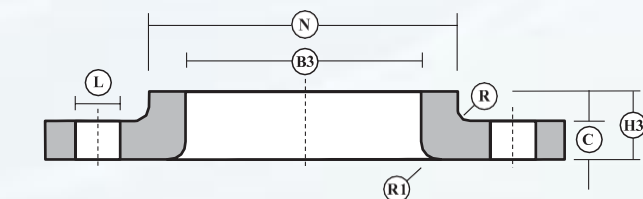

Lapped Flange

### ASME/ANSI B16.5-1988 Dimensions of Class 600 Flanges

N B Size INS MM	D	K	L	A	C	N	H1	H2	H3	H4	T	B1	B2	B3	R	R1	U	O	F	No. Holes
1/2 15	95	66.7	15.9	21.3	14.3	38	22.2	52.4	22.2		16	22.4		23	3	3	9.5	34.9	6.4	4
3/4 20	117	82.6	19	26.7	15.9	48	25.4	57.2	25.4		16	27.7		28	3	3	11	42.9	6.4	4
1 25	124	88.9	19	33.4	17.5	54	27	61.9	27		17	34.5		35	3	3	12.5	50.8	6.4	4
1 1/4 32	133	98.4	19	42.2	20.6	64	28.6	66.8	28.6		21	43.2		43.5	3	5	14.5	63.5	6.4	4
1 1/2 40	156	114.3	22.2	48.3	22.2	70	31.8	69.9	31.8		22	49.5		50	3	6.5	16	73	6.4	4
2 50	165	127	19	60.3	25.4	84	36.5	73	36.5		29	62		62.5	3	8	17.5	92.1	6.4	8
2 1/2 65	190	149.2	22.2	73	28.6	100	41.3	79.4	41.3		32	74.7		75.5	3	8	19	104.8	6.4	8
3 80	210	168.3	22.2	88.9	31.8	117	46	82.6	46		35	90.7		91.5	3	9.5	20.5	127	6.4	8
*3 1/2 88	228.6	184.2	25.4	101.6	35	133.4	49.3	85.9	49.3		39.6	103.4		104.1	3	9.5	-	139.7	6.4	8
4 100	273	215.9	25.4	114.3	38.1	152	54	101.6	54		41	116.1		117	3	11	-	157.2	6.4	8
5 125	330	266.7	28.6	141.3	44.4	189	60.3	114.3	60.3		48	143.8		145	6.5	11	-	185.7	6.4	8
6 150	356	292.1	28.6	168.3	47.6	222	66.8	117.5	66.8		51	170.7		171	6.5	12.5	-	215.9	6.4	12
8 200	419	349.2	31.8	219.1	55.6	273	76.2	133.4	76.2		-	221.5		222	6.5	12.5	-	269.9	6.4	12
10 250	508	431.8	34.9	273	63.5	343	85.7	152.4	111.1		-	276.4		277	6.5	12.5	-	323.8	6.4	16
12 300	559	489	34.9	323.9	66.7	400	92.1	155.6	117.5		-	327.2		328	11	12.5	-	381	6.4	20
14 350	603	527	38.1	355.6	69.8	432	93.7	165.1	127		-	359.2		360	11	12.5	-	412.7	6.4	20
16 400	686	603.2	41.3	406.4	76.2	495	106.4	177.8	139.7		-	410.5		411	11	12.5	-	469.9	6.4	20
18 450	743	654	44.4	457.2	82.6	546	117.5	184.2	151.4		-	461.8		462	11	12.5	-	533.4	6.4	20
20 500	813	723.9	44.4	508	88.9	610	127	190.5	165.1		-	513.1		514	11	12.5	-	584.2	6.4	24
24 600	940	838.2	50.8	609.6	101.6	718	139.7	203.2	184.2		-	616		616	11	12.5	-	692.1	6.4	24

**Note:** 3.5 Nominal bore Dimensions are Specified only in ASME/ANSI B16.5

### ASME/ANSI B16.5 Dimensions of Class 900 Flanges

N B Size INS MM	D	K	L	A	C	N	H1	H2	H3	H4	T	B1	B2	B3	R	R1	O	F	No. Holes
3 80	241	190.5	25.4	88.9	38.1	127	54	101.6	54		41	90.7		91.5	3	9.5	127	6.4	8
4 100	292	235	31.8	114.3	44.4	159	69.9	114.3	69.9		48	116.1		117	5	11	157.2	6.4	8
5 125	349	279.4	34.9	141.3	50.8	190	79.4	127	79.4		54	143.8		145	6.5	11	185.7	6.4	8
6 150	381	317.5	31.8	168.3	55.6	235	85.7	139.7	85.7		57	170.7		171	6.5	12.5	215.9	6.4	12
8 200	470	393.7	38.1	219.1	63.5	298	101.6	162	114.3		-	221.5		222	6.5	12.5	269.9	6.4	12
10 250	546	469.9	38.1	273	69.8	368	108	184.2	127		-	276.4		277	6.5	12.5	323.8	6.4	16
12 300	610	533.4	38.1	323.9	79.4	419	117.5	200	142.9		-	327.2		328	9.5	12.5	381	6.4	20
14 350	641	558.8	41.3	355.6	85.7	451	130.2	212.8	155.6		-	359.2		360	11	12.5	412.7	6.4	20
16 400	705	616	44.4	406.4	88.9	508	133.4	215.9	165.1		-	410.5		411	11	12.5	469.9	6.4	20
18 450	787	685.8	50.8	457.2	101.6	565	152.4	228.6	190.5		-	461.8		462	11	12.5	533.4	6.4	20
20 500	857	749.3	54	508	108	622	158.8	247.7	209.6		-	513.1		514	11	12.5	584.2	6.4	20
24 600	1041	901.7	66.7	609.6	139.7	749	203.2	292.1	266.7		-	616		616	11	12.5	692.1	6.4	20

**Note:** For Size 10mm-50mm Nominal bore use Class 1500 Dimensions



### ASME/ANSI B16.5

### DIMENSION OF CLASS 1500 & 2500 FLANGES

Note: This Diagram illustrates the Correct Position but not Necessarily the Correct Number of Bolt Holes

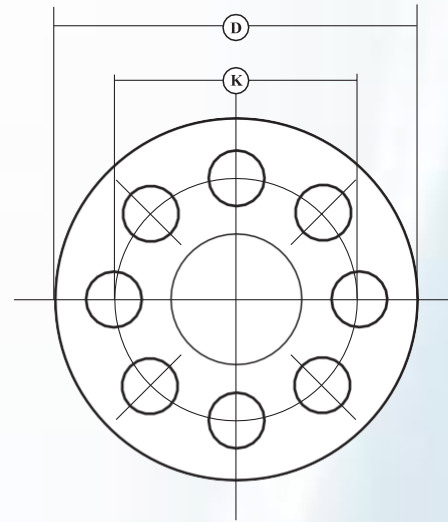

Steel Welding Neck Flange

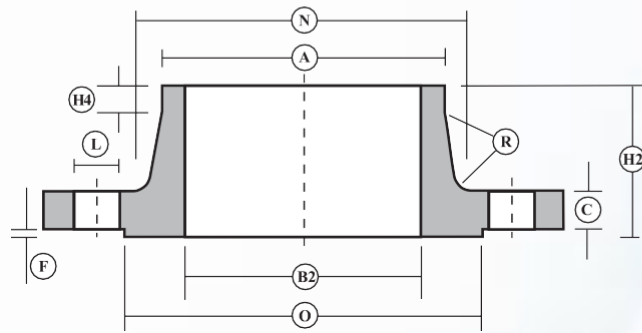

Socket Welding Flange

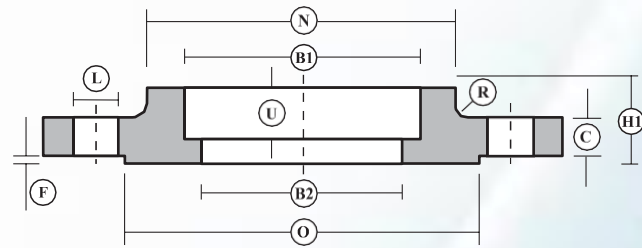

Screwed Boss Flange

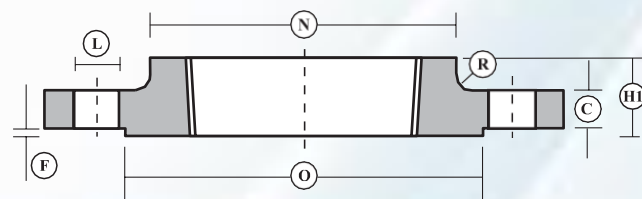

Slip-on Boss Flange

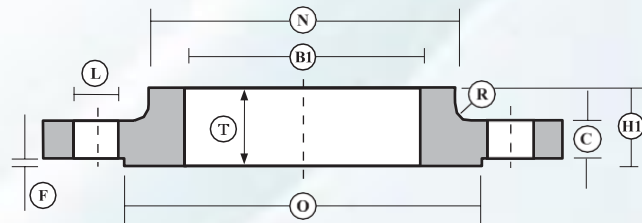

Steel Plate Blind Flange

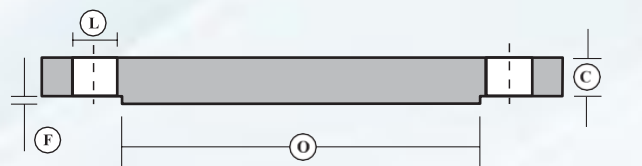

Lapped Flange

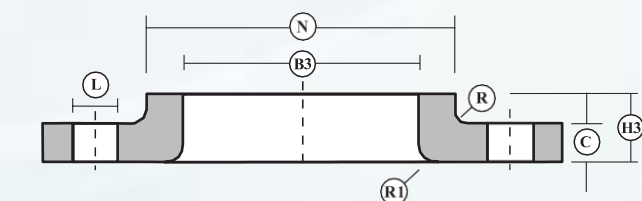

### ASME/ANSI B16.5 Dimensions of Class 1500 Flanges

N B Size	D	K	L	A	C	N	H1	H2	H3	H4	T	B1	B2	B3	R	R1	U	O	F	No. Holes
INS MM																				
1/2 15	121	82.6	22.2	21.3	22.2	38	31.8	60.3	31.8	-	22	22.4	-	23	5	3	9.5	34.9	6.4	4
3/4 20	130	88.9	22.2	26.7	25.4	44	34.9	69.9	34.9	-	25	27.7	-	28	5	3	11	42.9	6.4	4
1 25	149	101.6	25.4	33.4	28.6	52	41.3	73	41.3	-	29	34.5	-	35	5	3	12.5	50.8	6.4	4
1 1/4 32	159	111.1	25.4	42.2	28.6	64	41.3	73	41.3	-	30	43.2	-	43.5	5	5	14.5	63.5	6.4	4
1 1/2 40	178	123.8	28.6	48.3	31.8	70	44.5	82.6	44.5	-	32	49.5	-	50	5	6.5	16	73	6.4	4
2 50	216	165.1	25.4	60.3	38.1	105	57.2	101.6	57.2	-	38	62	-	62.5	5	8	17.5	92.1	6.4	8
2 1/2 65	244	190.5	28.6	73	41.3	124	63.5	104.8	63.5	-	48	74.7	-	75.5	5	8	19	104.8	6.4	8
3 80	267	203.2	31.8	88.9	47.6	133	73	117.5	73	-	51	90.7	-	91.5	5	9.5	-	127	6.4	8
4 100	311	241.3	34.9	114.3	54	162	90.5	123.8	90.5	-	57	116.1	-	117	5	11	-	157.2	6.4	8
5 125	375	292.1	41.3	141.3	73	197	104.8	155.6	104.8	-	64	143.8	-	145	6.5	11	-	185.7	6.4	8
6 150	394	317.5	38.1	168.3	82.6	229	119.1	171.5	119.1	-	70	170.7	-	171	6.5	12.5	-	215.9	6.4	12
8 200	483	393.7	44.4	219.1	92.1	292	142.9	212.7	142.9	-	-	221.5	-	222	6.5	12.5	-	269.9	6.4	12
10 250	584	482.6	50.8	273	108	368	158.8	254	177.8	-	-	276.4	-	277	9.5	12.5	-	323.8	6.4	12
12 300	673	571.5	54	323.9	123.8	451	181	282.6	219.1	-	-	327.2	-	328	11	12.5	-	381	6.4	16
14 350	749	635	60.3	355.6	133.4	495	-	298.5	241.3	-	-	359.2	-	360	11	12.5	-	412.7	6.4	16
16 400	826	704.8	66.7	406.4	146.1	552	-	311.2	260.4	-	-	410.5	-	411	11	12.5	-	469.9	6.4	16
18 450	914	774.7	73	457.2	161.9	597	-	327	276.2	-	-	461.8	-	462	11	12.5	-	533.4	6.4	16
20 500	984	831.8	79.4	508	178	641	-	355.6	292.1	-	-	513.1	-	514	11	12.5	-	584.2	6.4	16
24 600	1168	990.6	92	609.6	203	762	-	406.4	330.2	-	-	616	-	616	11	12.5	-	692.1	6.4	16

B&I 560- Section 3.1 : 1989  
ASME/ANSI B16.5-1989

### ASME/ANSI B16.5 Dimensions of Class 2500 Flanges

N B Size	D	K	L	A	C	N	H1	H2	H3	H4	T	B2	B3	R	R1	O	F	No. Holes
INS MM																		
1/2 15	133	88.9	22.2	21.3	30.2	43	39.7	73	39.7	-	29	-	23	5	3	34.9	6.4	4
3/4 20	140	95.2	22.2	26.7	31.7	51	42.9	79.4	42.9	-	32	-	28	5	3	42.9	6.4	4
1 25	159	107.9	25.4	33.4	34.9	57	47.6	88.9	47.6	-	35	-	35	5	3	50.8	6.4	4
1 1/4 32	184	130.2	28.6	42.2	38.1	73	52.4	95.3	52.4	-	38	-	43.5	5	5	63.5	6.4	4
1 1/2 40	203	146	31.8	48.3	44.4	79	60.3	111.1	60.3	-	44	-	50	9.5	6.5	73	6.4	4
2 50	235	171.4	28.6	60.3	50.8	95	69.9	127	69.9	-	51	-	62.5	9.5	8	92.1	6.4	8
2 1/2 65	267	196.8	31.8	73	57.1	114	79.4	142.9	79.4	-	57	-	75.5	9.5	8	104.8	6.4	8
3 80	305	228.6	34.9	88.9	66.7	133	92.1	168.3	92.1	-	64	-	91.5	9.5	9.5	127	6.4	8
4 100	356	273	41.3	114.3	76.2	165	108	190.5	108	-	70	-	117	9.5	11	157.2	6.4	8
5 125	419	323.8	47.6	141.3	92.1	203	130.2	228.6	130.2	-	76	-	145	9.5	11	185.7	6.4	8
6 150	483	368.3	54	168.3	108	235	152.4	273.1	152.4	-	83	-	171	15.5	12.5	215.9	6.4	8
8 200	552	438.1	54	219.1	127	305	-	317.5	177.8	-	-	-	222	15.5	12.5	269.9	6.4	12
10 250	673	539.7	66.7	273	165.1	375	-	419.1	228.6	-	-	-	277	15.5	12.5	323.8	6.4	12
12 300	672	619.1	73	323.9	184.1	441	-	463.6	254	-	-	-	328	15.5	12.5	381	6.4	12



# NUMBER & SIZE OF BOLTS FOR FLANGED JOINTS - ASME B16.5

Lengths of studs and bolts, when used with lap joint flanges, are dependent upon the thickness of the lap of the stub end. Stud-Bolt lengths do not include the height of the points.

PRIMARY SERVICE PRESSURE RATING	BOLTING	FLANGE FACING	NOMINAL PIPE SIZE																			
			1/2	3/4	1	1 1/4	1 1/2	2	2 1/2	3	3 1/2	4	5	6	8	10	12	14	16	18	20	24
Class 150	Number		4	4	4	4	4	4	4	4	8	8	8	8	8	12	12	12	16	16	20	20
	Diameter		1/2	1/2	1/2	1/2	1/2	5/8	5/8	5/8	5/8	5/8	3/4	3/4	3/4	7/8	7/8	1	1	1 1/8	1 1/8	1 1/4
	Length of Stud Bolts	1/16" RF	2 1/4	2 1/2	2 1/2	2 3/4	2 3/4	3 1/4	3 1/2	3 1/2	3 1/2	3 1/2	3 3/4	4	4 1/4	4 1/2	4 3/4	5 1/4	5 1/4	5 3/4	6 1/4	6 3/4
		RTJ			3	3 1/4	3 1/4	3 3/4	4	4	4	4	4 1/4	4 1/2	4 3/4	5	5 1/4	5 3/4	6 1/4	6 3/4	7 1/4	
	Length of Mach. Bolts	1/16" RF	2	2	2 1/4	2 1/4	2 1/2	2 3/4	3	3	3	3	3 1/4	3 1/4	3 1/2	4	4	4 1/2	4 1/2	5	5 1/2	6
Ring No.				R15	R17	R19	R22	R25	R29	R33	R36	R40	R43	R48	R52	R56	R59	R64	R68	R72	R76	
Class 300	Number		4	4	4	4	4	8	8	8	8	8	8	12	12	16	16	20	20	24	24	24
	Diameter		1/2	5/8	5/8	5/8	3/4	5/8	3/4	3/4	3/4	3/4	3/4	3/4	7/8	1	1 1/8	1 1/8	1 1/4	1 1/4	1 1/4	1 1/2
	Length of Stud Bolts	1/16" RF	2 1/2	3	3	3 1/4	3 1/2	3 1/2	4	4 1/4	4 1/4	4 1/2	4 3/4	4 3/4	5 1/2	6 1/4	6 3/4	7	7 1/2	7 3/4	8	9
		RTJ	3	3 1/2	3 1/2	3 3/4	4	4	4 1/2	4 3/4	5	5	5 1/4	5 1/2	6	6 3/4	7 1/4	7 1/2	8	8 1/4	8 3/4	10
	Length of Mach. Bolts	1/16" RF	2 1/4	2 1/2	2 1/2	2 3/4	3	3	3 1/4	3 1/2	3 3/4	3 3/4	4 1/4	4 1/4	4 3/4	5 1/2	5 3/4	6 1/4	6 1/2	6 3/4	7 1/4	8
Ring No.		R11	R13	R16	R18	R20	R23	R26	R31	R34	R37	R41	R45	R49	R53	R57	R61	R65	R69	R73	R77	
Class 400	Number		4	4	4	4	4	8	8	8	8	8	8	12	12	16	16	20	20	24	24	24
	Diameter		1/2	5/8	5/8	5/8	3/4	5/8	3/4	3/4	7/8	7/8	7/8	7/8	1	1 1/8	1 1/4	1 1/4	1 3/8	1 3/8	1 1/2	1 3/4
	Length of Stud Bolts	1/4" RF	3	3 1/2	3 1/2	3 3/4	4 1/4	4 1/4	4 3/4	5	5 1/2	5 1/2	5 3/4	6	6 3/4	7 1/2	8	8 1/4	8 3/4	9	9 1/2	10 1/2
		M & F T & G	2 3/4	3 1/4	3 1/4	3 1/2	4	4	4 1/2	4 3/4	5 1/4	5 1/4	5 1/4	5 3/4	6 1/2	7 1/4	7 3/4	8	8 1/2	8 3/4	9 1/4	10 1/4
		RTJ	3	3 1/2	3 1/2	3 3/4	4 1/4	4 1/4	4 3/4	5	5 1/2	5 1/2	5 3/4	6	6 3/4	7 1/2	8	8 1/4	8 3/4	9	9 3/4	11
Ring No.		R11	R13	R16	R18	R20	R23	R26	R31	R34	R37	R41	R45	R49	R53	R57	R61	R65	R69	R73	R77	
Class 600	Number		4	4	4	4	4	8	8	8	8	8	8	12	12	16	16	20	20	20	24	24
	Diameter		1/2	5/8	5/8	5/8	3/4	5/8	3/4	3/4	7/8	7/8	1	1	1 1/8	1 1/4	1 1/4	1 3/8	1 1/2	1 5/8	1 5/8	1 7/8
	Length of Stud Bolts	1/4" RF	3	3 1/2	3 1/2	3 3/4	4 1/4	4 1/4	4 3/4	5	5 1/2	5 3/4	6 1/2	6 3/4	7 1/2	8 1/2	8 3/4	9 1/4	10	10 3/4	11 1/4	13
		M & F T & G	2 3/4	3 1/4	3 1/4	3 1/2	4	4	4 1/2	4 3/4	5 1/4	5 1/2	6 1/4	6 1/2	7 1/4	8 1/4	8 1/2	9	9 3/4	10 1/2	11	12 3/4
		RTJ	3	3 1/2	3 1/2	3 3/4	4 1/4	4 1/4	4 3/4	5	5 1/2	5 3/4	6 1/2	6 3/4	7 3/4	8 1/2	8 3/4	9 1/4	10	10 3/4	11 1/2	13 1/4
Ring No.		R11	R13	R16	R18	R20	R23	R26	R31	R34	R37	R41	R45	R49	R53	R57	R61	R65	R69	R73	R77	
Class 900	Number		4	4	4	4	4	8	8	8		8	8	12	12	16	16	20	20	20	20	20
	Diameter		3/4	3/4	7/8	7/8	1	7/8	1	7/8		1 1/8	1 1/4	1 1/8	1 3/8	1 3/8	1 3/8	1 1/2	1 5/8	1 7/8	2	2 1/2
	Length of Stud Bolts	1/4" RF	4 1/4	4 1/2	5	5	5 1/2	5 3/4	6 1/4	5 3/4		6 3/4	7 1/2	7 1/2	8 3/4	9 1/4	10	10 3/4	11 1/4	12 3/4	13 3/4	17 1/4
		M & F T & G	4	4 1/4	4 3/4	4 3/4	5 1/4	5 1/2	6	5 1/2		6 1/2	7 1/4	7 1/4	8 1/2	9	9 3/4	10 1/2	11	12 1/2	13 1/2	17
		RTJ	4 1/4	4 1/2	5	5	5 1/2	5 3/4	6 1/4	5 3/4		6 3/4	7 1/2	7 3/4	8 3/4	9 1/4	10	11	11 1/2	13 1/4	14 1/4	18
Ring No.		R12	R14	R16	R18	R20	R24	R27	R31		R37	R41	R45	R49	R53	R57	R62	R66	R70	R74	R78	
Class 1500	Number		4	4	4	4	4	8	8	8		8	8	12	12	12	16	16	16	16	16	16
	Diameter		3/4	3/4	7/8	7/8	1	7/8	1	1 1/8		1 1/4	1 1/2	1 3/8	1 5/8	1 7/8	2	2 1/4	2 1/2	2 3/4	3	3 1/2
	Length of Stud Bolts	1/4" RF	4 1/4	4 1/2	5	5	5 1/2	5 3/4	6 1/4	7		7 3/4	9 3/4	10 1/4	11 1/2	13 1/4	14 3/4	16	17 1/2	19 1/2	21 1/4	24 1/4
		M & F T & G	4	4 1/4	4 3/4	4 3/4	5 1/4	5 1/2	6	6 3/4		7 1/2	9 1/2	10	11 1/4	13	14 1/2	15 3/4	17 1/4	19 1/4	21	24
		RTJ	4 1/4	4 1/2	5	5	5 1/2	5 3/4	6 1/4	7		7 3/4	9 3/4	10 1/2	12 3/4	13 1/2	15 1/4	16 3/4	18 1/2	20 3/4	22 1/4	25 1/2
Ring No.		R12	R14	R16	R18	R20	R24	R27	R35		R39	R44	R46	R50	R54	R58	R63	R67	R71	R75	R79	
Class 2500	Number		4	4	4	4	4	8	8	8		8	8	8	12	12	12					
	Diameter		3/4	3/4	7/8	1	1 1/8	1	1 1/8	1 1/4		1 1/2	1 3/4	2	2	2 1/2	2 3/4					
	Length of Stud Bolts	1/4" RF	4 3/4	5	5 1/2	6	6 3/4	7	7 3/4	8 3/4		10	11 3/4	13 1/2	15	19 1/4	21 1/4					
		M & F T & G	4 1/2	4 3/4	5 1/4	5 3/4	6 1/2	6 3/4	7 1/2	8 1/2		9 3/4	11 1/2	13 1/4	14 3/4	19	21					
Ring No.	RTJ	R13	R16	R18	R21	R23	R26	R28	R32		R38	R42	R47	R51	R55	R60						

## THREADED OUTLETS

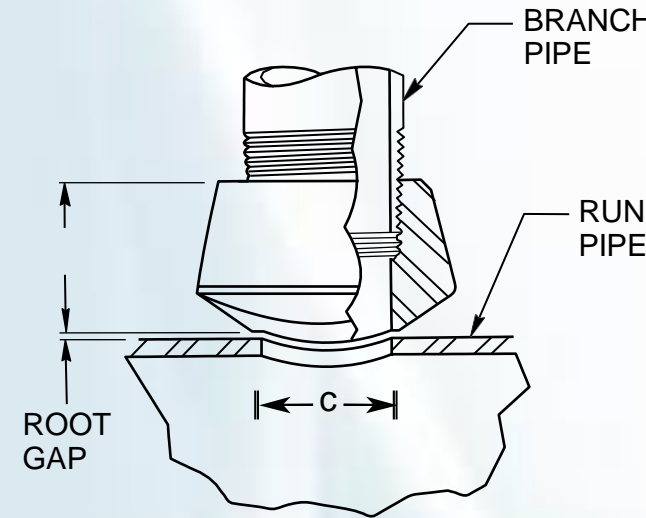

Outlet Size NPS	Dimensions					
	Class 3000			Class 6000		
	A	C	Weight	A	C	Weight
1/8	3/4	.328	0.07	1-1/8	.157	0.15
1/4	3/4	.438	0.12	1-1/8	.250	0.30
3/8	13/16	.563	0.16	1-1/8	.359	0.30
1/2	1	.703	0.21	1-1/4	.464	0.42
3/4	1-1/16	.906	0.36	1-7/16	.612	0.71
1	1-5/16	1.141	0.59	1-9/16	.815	1.25
1-1/4	1-5/16	1.469	0.84	1-5/8	1.160	1.53
1-1/2	1-3/8	1.688	1.00	1-11/16	1.338	1.91
2	1-1/2	2.188	1.72	2-1/16	1.687	4.83
2-1/2	1-13/16	2.563	2.90	2-11/16	2.125	6.19
3	2	3.188	4.24	2-11/16	2.624	7.36
3-1/2	2-1/8	3.688	4.40	-	-	-
4	2-1/4	4.188	6.91	3-5/16	3.438	14.02
5	2-5/8	5.275	9.46	3-11/16	4.313	20.03
6	2-11/16	6.313	14.03	4-1/8	5.187	29.36

## SOCKET-WELD OUTLETS

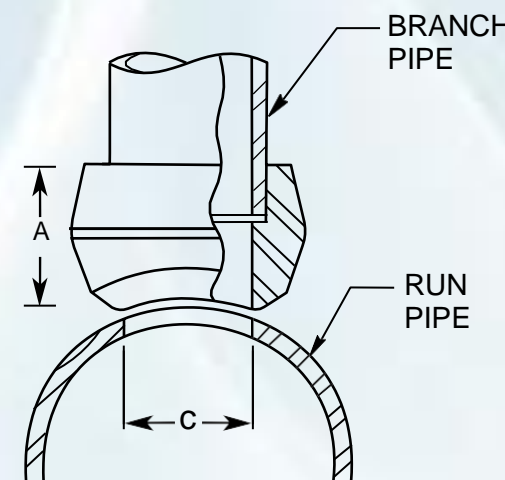

Outlet Size NPS	Dimensions					
	Class 3000			Class 6000		
	A	C	Weight	A	C	Weight
1/8	3/4	.269	0.07	1-1/8	.157	0.15
1/4	3/4	.364	0.12	1-1/8	.250	0.30
3/8	13/16	.493	0.16	1-1/8	.359	0.30
1/2	1	.622	0.27	1-1/4	.464	0.48
3/4	1-1/16	.824	0.36	1-7/16	.612	0.81
1	1-5/16	1.049	0.59	1-9/16	.815	1.30
1-1/4	1-5/16	1.380	0.84	1-5/8	1.160	1.54
1-1/2	1-3/8	1.610	1.00	1-11/16	1.338	1.97
2	1-1/2	2.067	1.53	2-1/16	1.687	5.01
2-1/2	1-13/16	2.469	2.66	2-11/16	2.125	6.19
3	2	3.068	3.72	2-11/16	2.624	7.36
3-1/2	2-1/8	3.548	4.40	-	-	-
4	2-1/4	4.026	7.05	3-5/16	3.438	14.02
5	2-5/8	5.047	9.46	3-11/16	4.313	20.03
6	2-11/16	6.065	14.03	4-1/8	5.187	29.36

## STANDARD & EXTRA HEAVY BUTT-WELD OUTLET

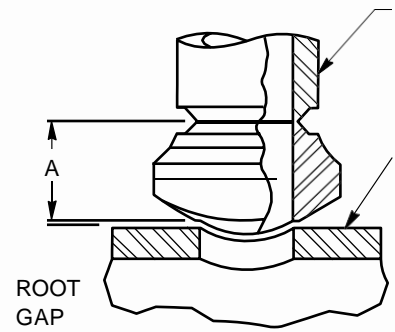

## SCHEDULE 160 & DOUBLE EXTRA HEAVY BUTT-WELD OUTLET

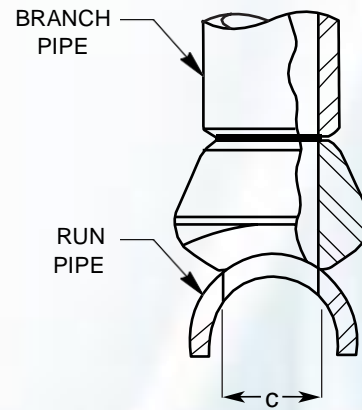

Outlet Size Inches	Dimensions									
	Standard			Extra Heavy			SCH160 XXH			
	A	C	WEIGHT	A	C	WEIGHT	A	C	C	WEIGHT
1/8	5/8	.269	.08	5/8	.215	.10				
1/4	5/8	.364	.08	5/8	.302	.08				
3/8	3/4	.493	.15	3/4	.423	.15				
1/2	3/4	.622	.18	3/4	.546	.20	1-1/8	.466	.252	.23
3/4	7/8	.824	.25	7/8	.742	.31	1-1/4	.614	.434	.65
1	1-1/6	1.049	.50	1-1/16	.957	.55	1-1/2	.815	.599	.78
1-1/4	1-1/4	1.380	.80	1-1/4	1.278	.90	1-3/4	1.160	.896	1.16
1-1/2	1-5/16	1.610	1.00	1-5/16	1.500	1.10	2	1.338	1.100	1.60
2	1-1/2	2.067	1.75	1-1/2	1.939	1.75	2-3/16	1.689	1.503	1.95
2-1/2	1-5/8	2.469	2.50	1-5/8	2.323	2.28	2-7/16	2.124	1.771	3.02
3	1-3/4	3.068	3.82	1-3/4	2.900	3.50	2-7/8	2.624	2.300	5.75
3-1/2	1-7/8	3.548	5.10	1-7/8	3.364	4.75				
4	2	4.026	6.20	2	3.826	5.00	3-7/16	3.438	3.152	9.56
5	2-1/4	5.047	8.00	2-1/4	4.813	8.50	3-11/16	4.313	4.063	12.65
6	2-3/8	6.065	11.50	3-1/16	5.761	15.00	4-1/8	5.189	4.897	25.25
8	2-3/4	7.981	22.00	3-7/8	7.625	35.00	*			
10	3-1/16	10.020	37.00	3-11/16	9.750	46.00	*			
12	3-3/8	12.000	44.00	4-1/16	11.750	63.00	*			
14	3-1/2	13.250	63.00	3-15/16	13.000	72.00	*			
16	3-11/16	15.250	76.00	4-3/16	15.000	102.00	*			
18	3-13/16	17.250	100.00	4-3/8	17.000	130.00	*			
20	4	19.250	112.00	4-11/16	19.000	163.00	*			
24	4-9/16	23.250	210.00	5-1/2	23.000	271.00	*			
26	4-11/16	25.250	245.00	5-3/4	25.000	325.00	*			
30	5-3/8	29.250	375.00				*			
36	5-3/8	35.250	498.00				*			
48	5-13/16	47.2502	1125.00				*			

## LATERAL & ELBOW CONNECTIONS (for 90 Degree Long Radius Pipe Elbows)

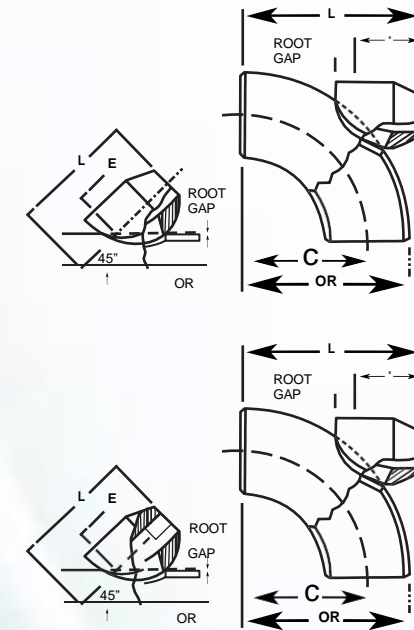

OUTLET SIZE NPS	Dimensions		
	STANDARD	EXTRA HEAVY	WEIGHT
1/4	1-5/8	1-5/8	0.49
3/8	1-5/8	1-5/8	0.50
1/2	1-5/8	1-5/8	0.52
3/4	1-7/8	1-7/8	1.00
1	2-1/4	2-1/4	1.26
1-1/4	2-1/2	2-1/2	1.39
1-1/2	2-11/16	2-11/16	1.53
2	3-1/8	3-1/8	2.76
2-1/2	3-7/16	3-7/16	4.70
3	3-7/8	3-7/8	6.54
4	4-3/4	4-3/4	12.31
6	6-1/4	7-1/16	24.25
8	7-3/4	8-7/8	60.00
10	9-3/16	9-15/16	90.50
12	10-1/2	11-7/2	121.00

\*L = E + 1.414 (O.R) where O.R. is the outside radius  
 \*\* L = E + √(O.R.<sup>2</sup> - A<sup>2</sup>)

## HEAVY WALL BUTT-WELD OUTLETS

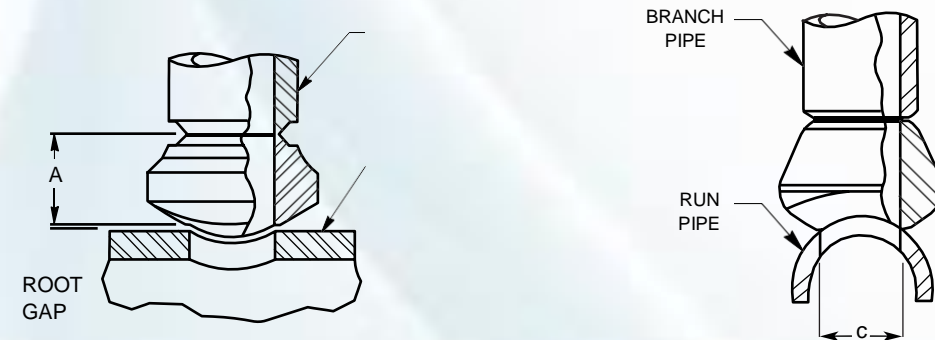

Outlet Size NPS	"A" DIMENSION									
	RUN WALL NOMINAL THICKNESS									
	3/4	1	1-1/4	1-1/2	1-3/4	2	2-1/4	2-1/2	2-3/4	3
3	2-7/8	3-1/4	3-3/8	3-5/8	4-1/8	4-9/16	5	5-1/2	5-7/8	6-1/16
3-1/2	3-1/8	3-1/4	3-7/16	3-3/4	4-3/16	4-5/8	5-1/16	5-9/16	6	6-5/16
4	3-5/16	3-3/8	3-1/2	3-7/8	4-5/16	4-3/4	5-3/16	5-5/8	6-1/8	6-9/16
5	3-3/4	3-3/4	4	4-1/4	4-3/4	5-1/4	5-3/4	6-1/4	6-5/8	7-3/16
6	4-1/8	4-3/8	4-1/2	4-11/16	5-1/14	5-3/4	6-1/4	6-3/4	7-1/4	7-13/16
8	4-3/16	4-5/8	4-7/8	5-3/16	5-3/4	6-3/8	6-15/16	7-1/2	8-1/8	8-11/16
10	4-1/4	4-7/8	5	5-5/16	5-15/16	6-9/16	7-3/16	7-13/16	8-7/16	9-1/16
12	4-3/8	5-1/8	5-3/8	5-11/16	6-5/16	6-15/16	7-9/16	8-3/16	8-13/16	9-7/16
14	4-1/2	5-1/4	5-1/2	5-13/16	6-5/16	6-15/16	7-9/16	8-3/16	8-13/16	9-7/16
16	4-11/16	5-7/8	6	6-7/16	6-5/8	7-1/4	7-7/8	8-1/2	9-1/8	9-3/4
18	5-1/8	6-1/2	6-1/2	6-1/2	6-13/16	7-7/16	8-1/4	8-13/16	9-7/16	10-1/16
20	5-5/8	6-3/4	7	7-9/16	7-13/16	8-1/8	8-11/16	9-1/4	9-15/16	10-1/2
24	6-1/2	7-5/8	8	8-3/4	9	9-13/16	10-1/2	11	12-9/16	10-11/16



# SWAGED NIPPLE

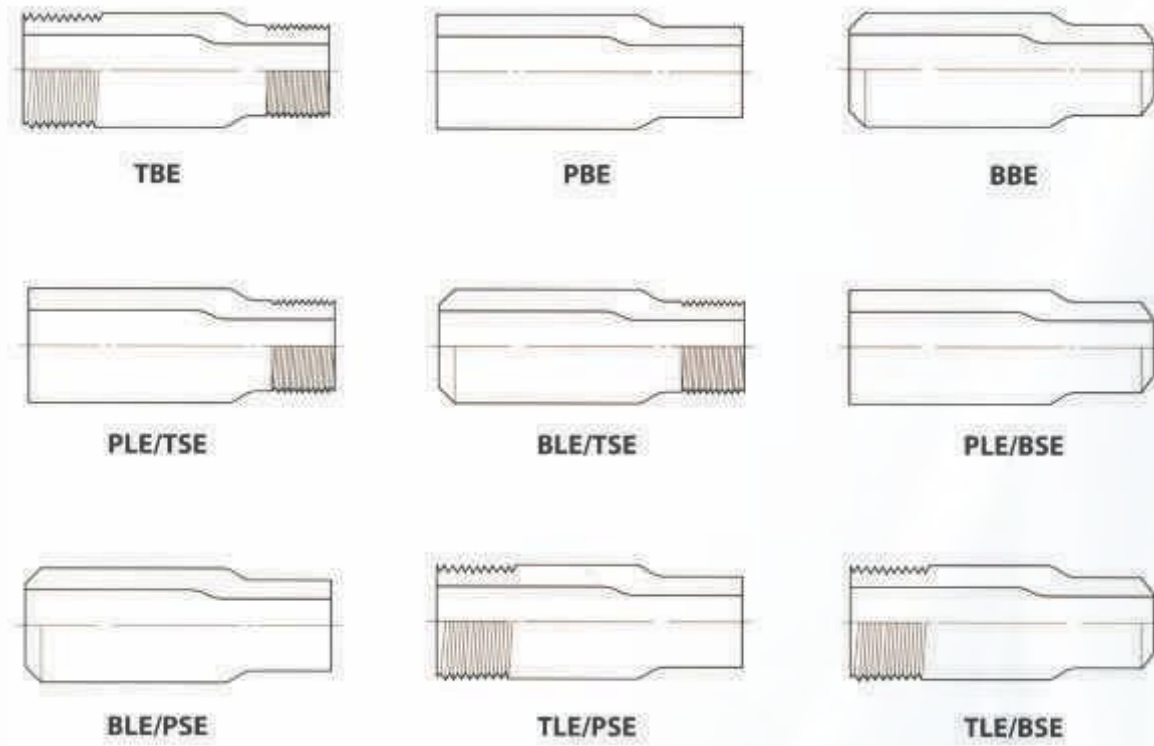

## MSS SP-95

Large end Size	Small end Size	Length (mm)
1/2	3/8 ~ 1/8	70
3/4	1/2 ~ 1/8	76
1	3/4 ~ 1/8	89
1 1/4	1 ~ 1/8	102
1 1/2	1 1/4 ~ 1/8	114
2	1 1/2 ~ 1/8	165
2 1/2	2 ~ 1/8	178
3	2 1/2 ~ 1/8	203
3 1/2	3 ~ 1/8	203
4	3 1/2 ~ 1/8	229
5	4 ~ 1/4	279
6	5 ~ 1/2	304

- BBE : Beveled both end
- TBE : Threaded both end
- PBE : Plane both end
- PLE / TSE : Plane large end - Threaded small end
- BLE / TSE : Beveled large end - Threaded small end
- TLE / PSE : Threaded large end - Plane small end
- BLE / PSE : Beveled large end - Plane small end
- PLE / BSE : Plane large end - Beveled small end
- TLE / BSE : Threaded large end - Beveled small end

- Pipe schedule numbers and weight designations accordance with ASME B36.10  
 - Swaged Nipples are from Forged Steel or Pipe

## SCHEMATIC DETAILS OF PRODUCTION PROCESS FOR FLANGES

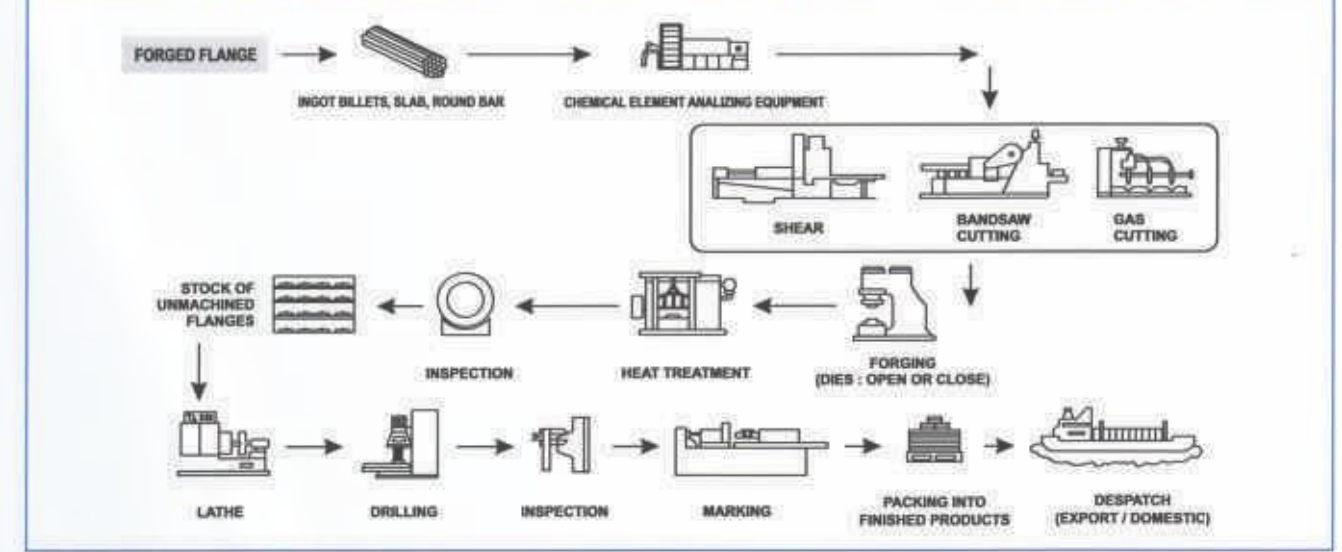

## SCHEMATIC DETAILS OF MANUFACTURING PROCEDURE OF BW PIPE FITTINGS

NOTE : 1) STAGE WISE & ONLINE INSPECTION AT EVERY STAGE AND PROCESS BY 100%

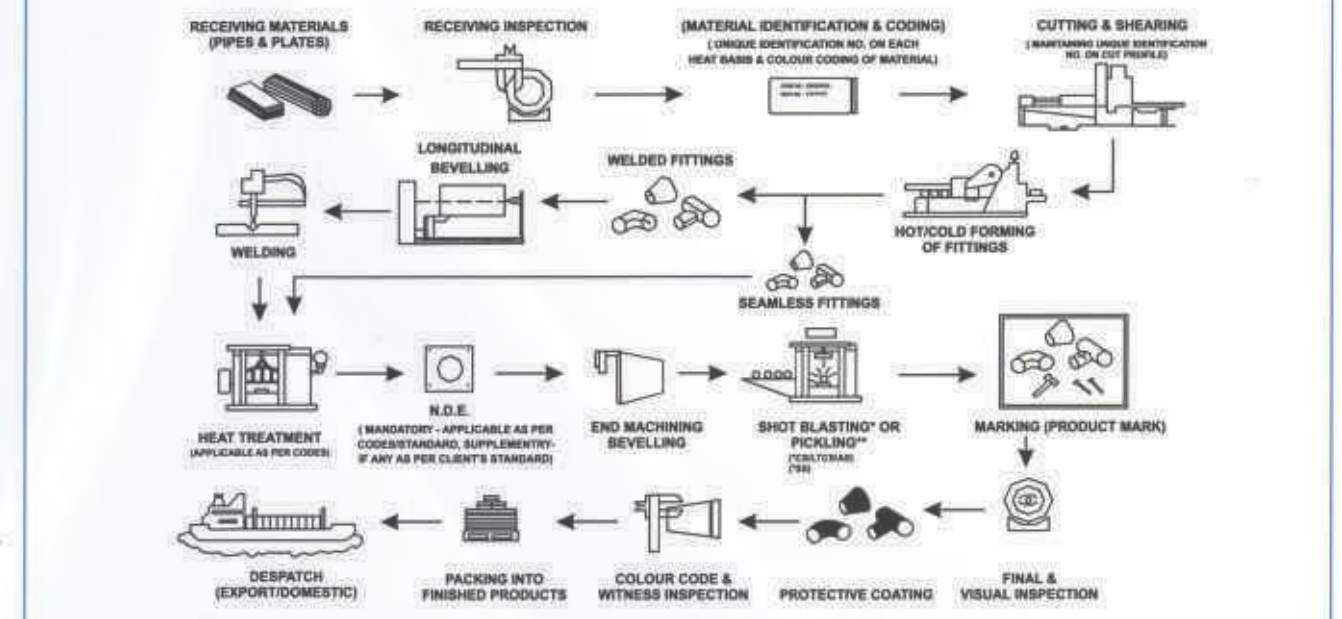

## SOCKETED MANUFACTURING FLOW CHART

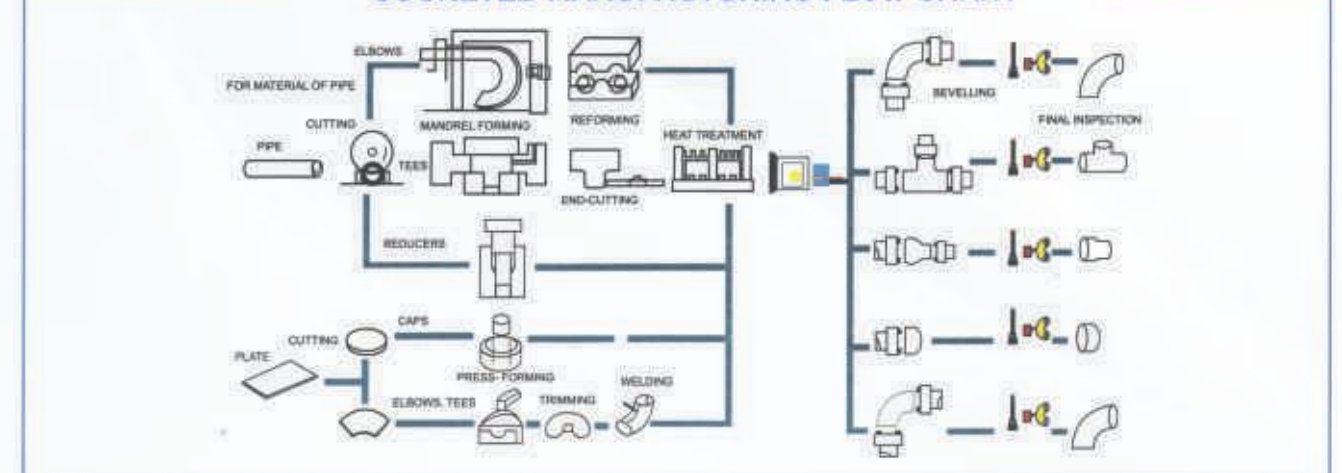



# FASTENER

## Common Fastener Types



**Hex bolts**, or hex cap screws, are used in machinery & construction. Can be used with a nut, or in a tapped hole. Fully threaded hex bolts are also known as tap bolts.



**Wood screws** have large threads and a smooth shank for pulling two pieces of material together. They can be used in wood and other soft materials.



**Sheet metal screws** have sharp points and threads, and are designed to be driven directly into sheet metal. They can also be used in softer materials like plastic, fiberglass, or wood.



**Machine screws** are fully treaded for use with a nut or in a tapped hole. Certain types are sometimes referred to as *stove bolts*.



**Socket screws** are machine screws with an internal hex socket (*Allen*) drive. Longer lengths may have a smooth shank.



**Lag bolts**, or *lag screws*, are large wood screws with hex heads. Typically used for wood construction and landscaping.



**Carriage bolts** have smooth, domed heads with a square section underneath that pulls into the material to prevent spinning during installation.



**Nuts** are used to fasten machine threaded fasteners in through-hole applications. *Lock nuts* help prevent loosening.



**Washers** spread the load over a greater surface area when tightening a bolt, screw or nut. *Lock washers* help preventing loosening.

## Grade / Class and Fastener Strength

Fastener Grade (US) or Class (metric) refers to the mechanical properties more hardened (but also more brittle) fastener. For a chart of fastener grades, head markings & mechanical properties,

### US bolt head markings



### Metric bolt head markings



**Note:** In addition to these markings, the head will often have a manufacturer stamp.

## Fastener Materials

**Note:** Do not rely on this guide for color-matching. The appearance of these materials sometimes differs.

**Zinc-plated steel** is a low carbon steel for general use. Relatively inexpensive, with the zinc plating providing moderate corrosion resistance suitable for indoors or otherwise dry conditions. Color is either a blue-ish tint or yellow depending on the exact process.

**Hot-dipped galvanized steel** has a thicker zinc coating for better corrosion resistance, making it suitable for outdoor use. Because of the thick plating, only galvanized nuts & washers will fit galvanized bolts. The coating typically has a rough, dull grey finish.

**Stainless steel** offers good corrosion resistance, making it suitable for outdoor and marine applications, but is more expensive than zinc plated.

**Chrome and nickel plated steel** are smooth and polished for appearance. The plating offers moderate corrosion resistance.

**Brass and bronze** are copper alloys with good corrosion resistance. More expensive than steel, these materials are typically used for decorative applications. Colors can vary significantly.

**Alloy steel** is highly hardened and usually black oxide and/or oil coated, offering little corrosion resistance.



## How Fasteners are Notated: An Example



Machine screws, Phillips pan head, Stainless steel 18-8, #12-24 x 1"

Fastener type

Material

Diameter

Length

Thread Count (TPI)

### Drive Types

- Phillips** Phillips and Slotted drives are common in screws, but prone to cam-out (stripping).
- Frearson** Combo drives, that can be used with either driver, are available for many fastener types.
- Pozidriv** Frearson and Pozidriv are similar to Phillips, but less prone to cam-out.
- Slotted** Hex socket (*Allen*) drives are compact and easy to drive, but prone to cam-out.
- Combo** Torx and Square drive are resistant to cam-out and can be installed singlehanded.
- Hex socket (Allen)** Note: Most drive types (Frearson and Slotted) require the correct driver size for proper installation.
- Square (Robertson)**
- Torx**

### Head Styles

- Hex heads** are typically used with larger bolts and screws, and tightened with a wrench.
- Pan heads** have a slightly domed head that sits above the surface.
- Flat heads** are installed in a countersunk hole for a flat surface.
- Round heads** are tall domed heads, used primarily for decorative purposes.
- Oval heads** are a low domed and countersunk heads, used primarily for decorative purposes.
- Truss heads** are slightly domed, with a wide head for an extra large surface area.
- Socket heads** are narrow with a socket drive, and knurled or smooth sides.
- Button heads** feature a medium dome. Typically used with a hex socket drive.

### Measuring Diameter

For most types of fasteners, the diameter is measured on the **outside of the threads**.

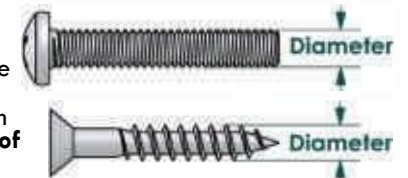

**Note:** US diameters under 1/4" are given as numbers (e.g. #12) instead of inches, in order of increasing size. If you need to find the actual diameter, use a table corresponding to your fastener type at [www.diptimetal.com](http://www.diptimetal.com)

### Thread Count & Thread Pitch

Machine threaded fasteners specify a thread density in **Threads Per Inch (US)** or as a **Thread Pitch** in mm (Metric).

For a given diameter, a fastener may be available in **coarse** (standard), **fine** and sometimes **super fine** thread.

### Measuring Length

Fastener length is usually measured from where the material is assumed to be to the end of the fastener.



Thus, countersunk fasteners are measured overall and non-countersunk fasteners are measured from under the head.

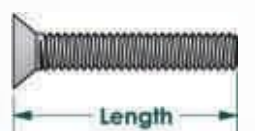

## Nut & Washer Sizes

Nut & washer sizes indicate **the screw or bolt they fit**. For example:



Different washer patterns have different outside diameters. For example, hardened US washers are available in USS (wider) & SAE (narrower) patterns. Fender washers have large outside diameters.

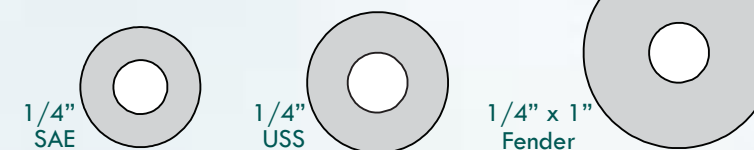

## More Information

- **In-depth fastener info**
- **Charts and tables**
- **Printable lay-over charts & tools** for quickly identifying fastener sizes and types
- Much more...





## FORMULA OF WEIGHT

### WEIGHT OF STAINLESS STEEL PIPES & TUBES

O.D. (mm) - W.T. (mm) x W.T. (mm) x 0.02466 = kg. / meter

### WEIGHT OF STAINLESS STEEL SHEETS

Length (Mtr.) x Width (Mtr.) x Thk (mm) x 8 = kg. / Sheet

### WEIGHT OF CARBON STAINLESS STEEL SHEETS

Length (mm) x Width (mm,) x Thk (mm) x 7.85 = kg. / Sheet

### WEIGHT OF STAINLESS STEEL CIRCLE & BLANKS

O.D. (mm) x O.D. (mm) x Thk (mm) / 160 / 1000 = kg. / Pcs.

### WEIGHT OF STAINLESS STEEL ROUNDS

Dia. (mm) x Dia. (mm) x 0.00623 = kg. / Meter.

### WEIGHT OF STAINLESS STEEL HEXAGONAL RODS

Dia. (Mm) x Dia. (mm) x 0.00679 = kg. / Meter.

### WEIGHT OF STAINLESS STEEL SQUARE RODS

Dia. (Mm) x Dia. (mm) x 0.00787 = kg. / Meter.

### WEIGHT OF COPPER PIPES

O.D. (mm) - W.T. (mm) x W.T. (mm) x 0.0285 = kg. / Meter.

### WEIGHT OF ALUMINIUM PIPES (appx.)

O.D. (mm) - W.T. (mm) x W.T. (mm) x 0.0082 = kg. / Meter.

### WEIGHT OF ALUMINIUM SHEETS (appx.)

Length (Mtr.) x Width (Mtr.) x Thk (mm) x 2.66 = kg. / Sheet

### WEIGHT OF LEAD SHEETS

Length (Mtr.) x Width (Mtr.) x Thk (mm) x 11.2 = kg. / MTR

### SHEETS WIDTH REQUIRED FOR ROLLED AND WELDED PIPES

O.D. (mm) - Thk (mm) x 3.14 = Sheet Width

### WEIGHT FOR SQUARE / RECTANGLE PIPES

Length from 4 Angle (OD) / 3.14 - Thk. (mm) x Thk. (mm) x 0.00756 = KG. / PER FEET

### WEIGHT FOR CONVERSION OF MTR. TO FEET

Weight of 1 Mtr. » 3.2808 = Feet

### FORMULA FOR HEALTHY BUSINESS

Honesty + Quality of Goods + Quick Service + Reasonable rate = Good Health of business

## APPLICATION INDUSTRY



- PHARMACY INDUSTRIES
- FOOD INDUSTRIES
- OIL & GAS INDUSTRIES
- TEXTILE INDUSTRIES
- CEMENT INDUSTRIES
- REFINERY PLANTS
- POWER
- FIRE FALLING SYSTEMS
- CHEMICAL
- FERTILIZERS
- PAPER & PULP MILLS
- SUGAR INDUSTRIES
- WATER PIPING SYSTEMS
- BEVERAGE INDUSTRIES
- ENGINEERING